



Workshop Manual

chassis

SUPPLEMENT

3000GT '96

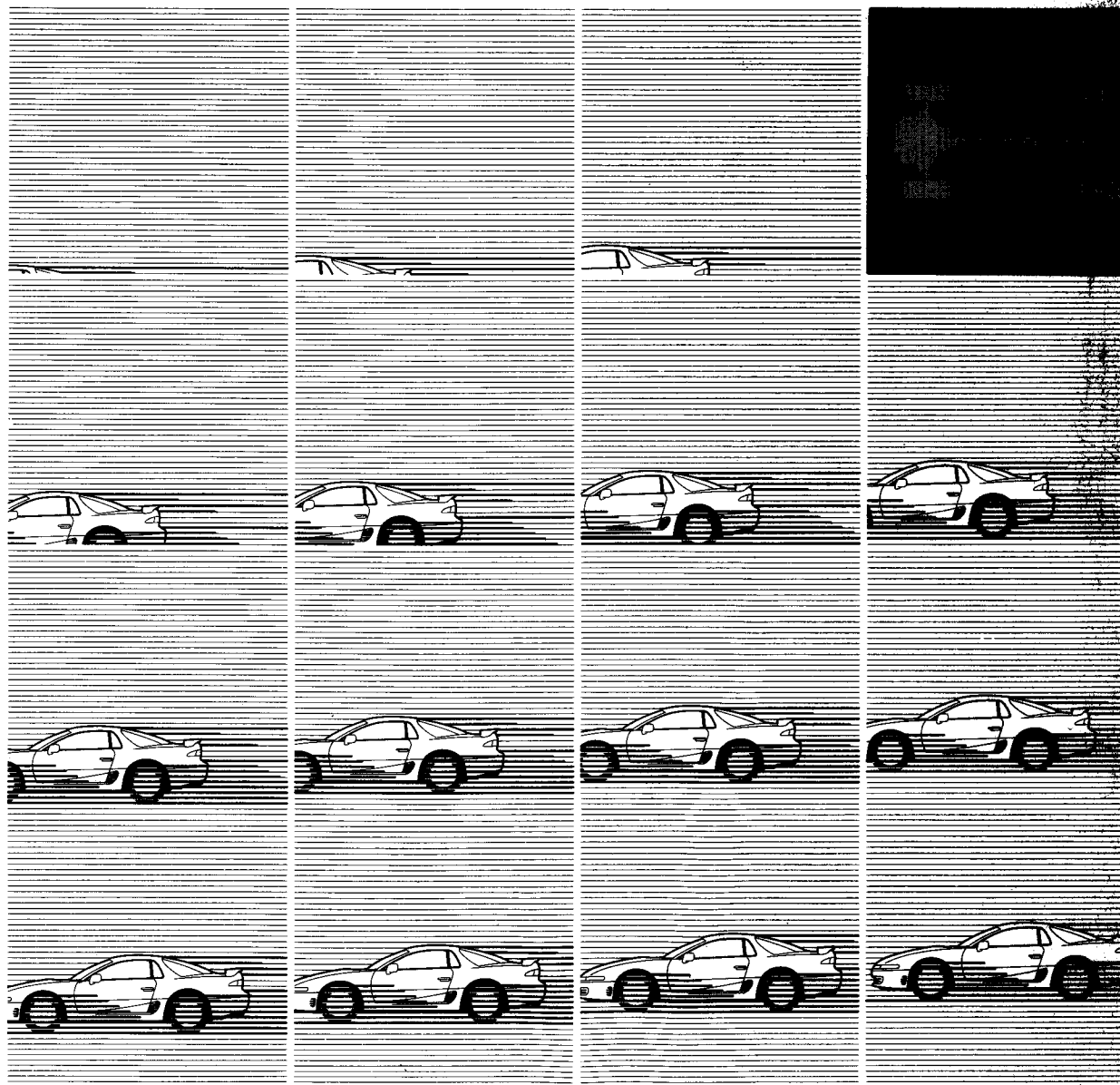

Pub. No. PWUE9119-E

Pub. No. PWUE9203-4

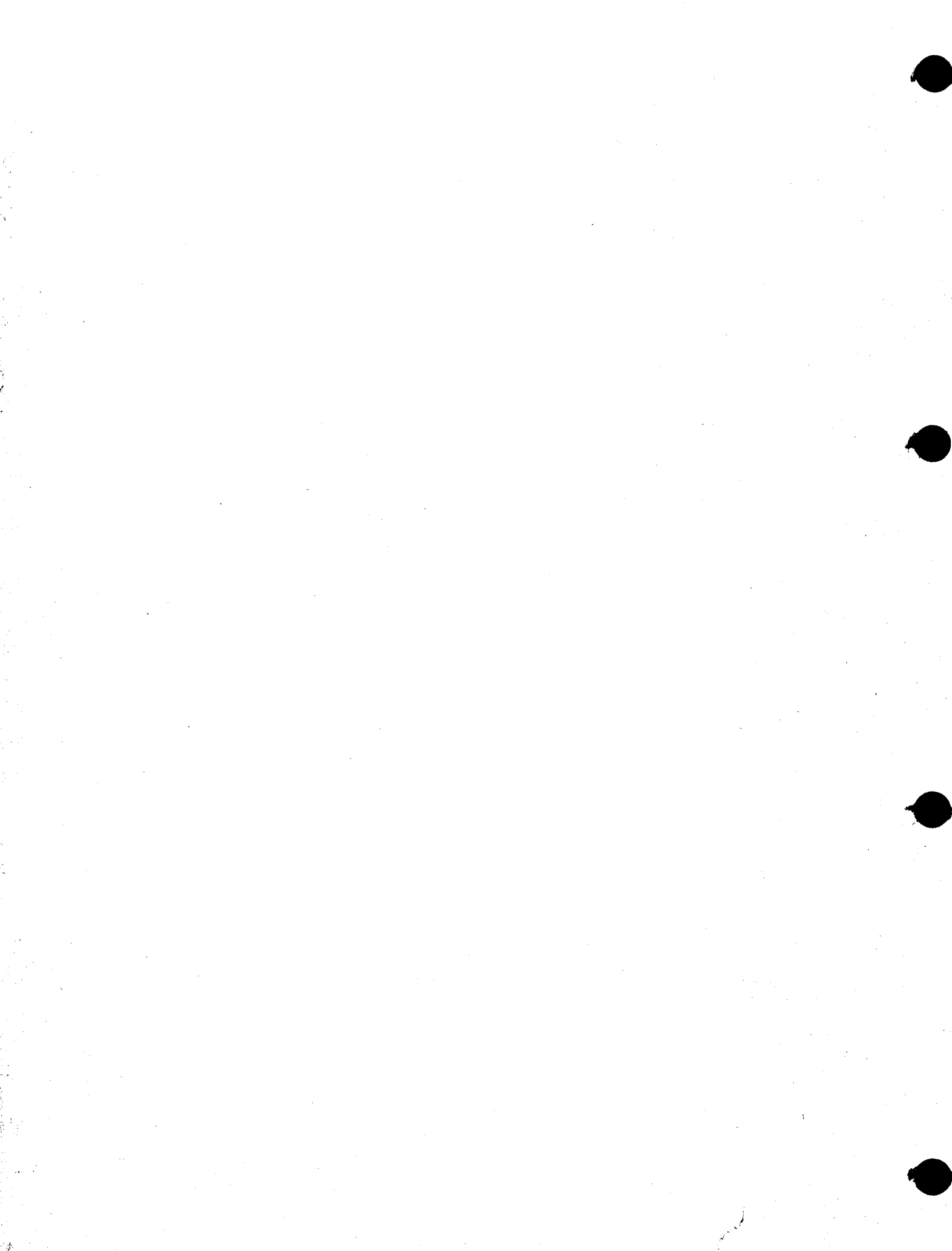

MITSUBISHI

3000GT

WORKSHOP MANUAL

SUPPLEMENT

FOREWORD

This Workshop Manual contains procedures for removal, disassembly, inspection, adjustment, reassembly and installation, etc. for service mechanics. Use the following manuals in combination with this manual as required.

TECHNICAL INFORMATION MANUAL
PYUE9201

WORKSHOP MANUAL
CHASSIS GROUP

PWUE9119
(Loose-leaf edition)
PWUE9203 (Basic)
PWUE9203-1
(Supplement)
PWUE9203-2
(Supplement)
PWUE9203-3
(Supplement)

ENGINE GROUP

PWEE□□□□
(Loose-leaf edition)

ELECTRICAL WIRING

PHUE9201
(Loose-leaf edition)
PHUE9406 (Basic)
PHUE9406-1
(Supplement)

PARTS CATALOGUE

B608K40□A□
B608K454A□
B608K406A□
B808K404A□
B808K454A□
BFA8K404A□
BFA8K454A□
B808K405A□
B808K406A□
BFA8K406A□

All information, illustrations and product descriptions contained in this manual are current as at the time of publication. We, however, reserve the right to make changes at any time without prior notice or obligation.

General	00
Fuel	13
Engine Electrical	16
Body	42
Chassis Electrical	54



WARNINGS REGARDING OF SUPPLEMENTAL RESTRAINT SYSTEM (SRS) EQUIPPED VEHICLES

WARNING!

- (1) Improper service or maintenance of any component of the SRS, or any SRS-related component, can lead to personal injury or death to service personnel (from inadvertent firing of the air bag) or to the driver (from rendering the SRS inoperative).**
- (2) If it is possible that the SRS components are subjected to heat over 93° C (200° F) in baking or in drying after painting, remove the SRS components (air bag module, SRS diagnosis unit, front impact sensors) beforehand.**
- (3) Service or maintenance of any SRS component or SRS-related component must be performed only at an authorized MITSUBISHI dealer.**
- (4) MITSUBISHI dealer personnel must thoroughly review this manual, and especially its GROUP 52B – Supplemental Restraint System (SRS), before beginning any service or maintenance of any component of the SRS or any SRS-related component.**

NOTE

Section titles with asterisks (*) in the table of contents in each group indicate operations requiring warnings.

GROUP 00
GENERAL

VEHICLE IDENTIFICATION

MODELS

VEHICLES FOR EUROPE

Model code	Engine model	Transmission model	Fuel supply system
Z16AMNGFL6	6G72 (2,972 ml)	W5MG1	MPI
Z16AMNGFR6			
Z16AMJGFL6		W6MG1	
Z16AMJGFR6			

VEHICLES FOR GENERAL EXPORT

Model code	Engine model	Transmission model	Fuel supply system
Z16AMNGFL	6G72 (2,972 ml)	W5MG1	MPI
Z16AMNGFR			

VEHICLES FOR GCC

Model code	Engine model	Transmission model	Fuel supply system
Z16AMNGFLW	6G72 (2,972 ml)	W5MG1	MPI

VEHICLES FOR AUSTRALIA

Model code	Engine model	Transmission model	Fuel supply system
Z16AMNGFR8	6G72 (2,972 ml)	W5G1	MPI

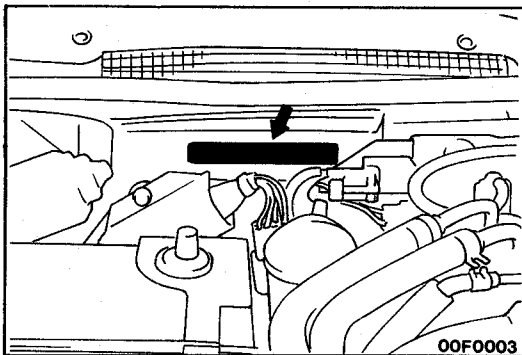

CHASSIS NUMBER

The chassis number is stamped on the toeboard inside the engine compartment.

<VEHICLES FOR EUROPE AND AUSTRALIA>

▲ **J M B M N Z16 A P Y 000001** ▲
 | | | | | | | | | |
 1 2 3 4 5 6 7 8 9 10

1. Asia
2. Japan
3. MITSUBISHI
 - A – For Europe, right hand drive
 - B – For Europe, left hand drive
 - F – For Australia, right hand drive
4. Body style
 - M – 2-door hatchback
5. Transmission type
 - N – 5-speed manual transmission
 - J – 6-speed manual transmission
6. Development order
 - Z16 – 2,972 ml (Full time 4WD)
7. Sort
 - A – Passenger car
8. Model year
 - P – 1993
 - R – 1994
 - S – 1995
 - T – 1996
9. Plant
 - Y – Ohe Motor Vehicle Works
10. Serial number

<VEHICLES FOR GENERAL EXPORT AND GCC>

C	M	N	Z16	A	P	Y	00001
1	2	3	4	5	6	7	8

1. MITSUBISHI
 - C – For General Export, right hand drive
 - D – For General Export or GCC, left hand drive
2. Body style
 - M – 2-door hatchback
3. Transmission type
 - N – 5-speed manual transmission
4. Development order
 - Z16 – 2,972 ml (Full time 4WD)
5. Sort
 - A – Passenger car
6. Model year
 - P – 1993
 - R – 1994
 - S – 1995
 - T – 1996
7. Plant
 - Y – Ohe Motor Vehicle Works
8. Serial number

MAJOR SPECIFICATIONS

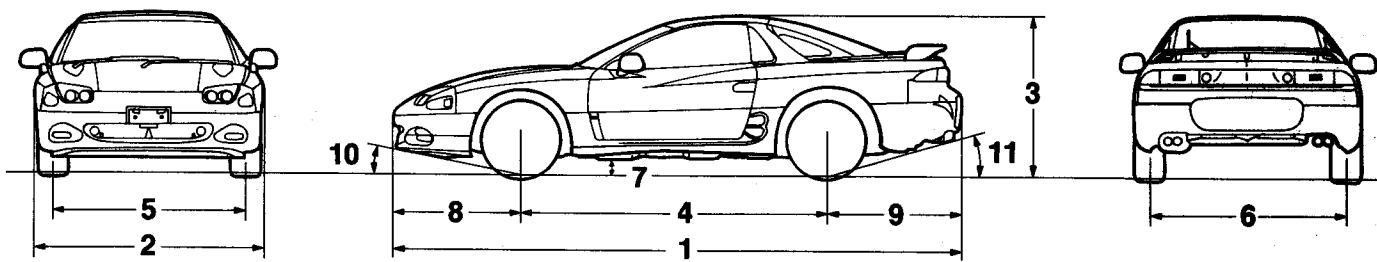

00F0064

Items		Z16AMNGFL6 Z16AMNGFR6	Z16AMJGFL6 Z16AMJGFR6	Z16AMNGFL Z16AMNGFR Z16AMNGFLW	Z16AMNGFR8
Dimensions	mm (in.)				
Overall length	1	4,570 (179.9)	4,570 (179.9)	4,570 (179.9)	4,570 (179.9)
Overall width	2	1,840 (72.4)	1,840 (72.4)	1,840 (72.4)	1,840 (72.4)
Overall height (unladen)	3	1,285 (50.6)	1,285 (50.6)	1,285 (50.6)	1,285 (50.6)
Wheelbase	4	2,470 (97.2)	2,470 (97.2)	2,470 (97.2)	2,470 (97.2)
Track – front	5	1,560 (61.4)	1,560 (61.4)	1,560 (61.4)	1,560 (61.4)
Track – rear	6	1,580 (62.2)	1,580 (62.2)	1,580 (62.2)	1,580 (62.2)
Ground clearance (unladen)	7	140 (5.5)	140 (5.5)	145 (5.7)	145 (5.7)
Overhang – front	8	1,030 (40.6)	1,030 (40.6)	1,030 (40.6)	1,030 (40.6)
Overhang – rear	9	1,070 (42.1)	1,070 (42.1)	1,070 (42.1)	1,070 (42.1)
Angle of approach degrees	10	11.0°	11.0°	12.0°	12.0°
Angle of departure degrees	11	17.6°	17.6°	17.4°	17.4°
Weight	kg (lbs.)				
Kerb weight		1,720 (3,792)	1,730 (3,858)	1,695 (3,737)	1,700 (3,748)
Gross vehicle weight		2,120 (4,674)	2,120 (4,674)	2,075 (4,575)	2,075 (4,575)
Max. axle weight					
front		1,150 (2,535)	1,150 (2,535)	1,150 (2,535)	1,150 (2,535)
rear		1,020 (2,249)	1,020 (2,249)	1,020 (2,249)	1,020 (2,249)
Seating capacity		4	4	4	4
Engine					
Model		6G72	6G72	6G72	6G72
Total displacement	ml	2,972	2,972	2,972	2,972
Transmission					
Model		W5MG1	W6MG1	W5MG1	W5MG1
Type		5-speed manual	6-speed manual	5-speed manual	5-speed manual

NOTES

FUEL

CONTENTS

GENERAL	2	ON-VEHICLE INSPECTION OF MPI	
Outline of Changes	2	COMPONENTS	4
SPECIFICATIONS	2	Fuel Pump	4
General Specifications	2	Air Conditioner Switch and Power Relay	8
TROUBLESHOOTING	2	Engine Control Unit Terminal	
Engine Warning Lamp		Voltage Check	9
(Check Engine Lamp)	2		
Self-diagnosis	2		
Problem Diagnosis Content Chart	2		
Check Chart Classified by			
Problem Symptoms	3		

GENERAL

OUTLINE OF CHANGES

The following maintenance service points have been established to correspond to the addition of vehicles with immobilizer system.

- An engine-ECU has been added.
- Engine warning lamp illumination details and self-diagnosis items have been added.
- Inspection procedures have been added for the fuel pump, air conditioner switch and power relay and for terminal voltages.

SPECIFICATIONS

GENERAL SPECIFICATIONS

Items		Specifications
Engine control unit Identification model No.	Europe LHD 6 M/T – Vehicles with immobilizer system	E2T61481
	Europe LHD 5 M/T – Vehicles with immobilizer system	E2T61483
	Europe RHD 6 M/T – Vehicles with immobilizer system	E2T61482
	Europe RHD 5 M/T – Vehicles with immobilizer system	E2T61484
	Australia – Vehicles with immobilizer system	E2T61486

TROUBLESHOOTING

ENGINE WARNING LAMP (CHECK ENGINE LAMP) ITEMS INDICATED BY THE ENGINE WARNING LAMP

Immobilizer system

SELF-DIAGNOSIS

Diagnosis Chart

Diagnosis item	Malfunction code		Check item (Remedy)
	No.	Memory	
Immobilizer system	54	Retained	(Inspect according to the troubleshooting procedures given in GROUP 54 – Ignition Switch and Immobilizer System.)

PROBLEM DIAGNOSIS CONTENT CHART

Malfunction code No.	Diagnosis item	Diagnosis contents	Probable cause	Remark (Trouble symptom, etc.)
54	Immobilizer system	Communication problem between the engine-ECU and the immobilizer-ECU	(1) Malfunction of communication wire between the engine-ECU and immobilizer-ECU (2) Malfunction of immobilizer-ECU (3) Malfunction of engine-ECU	• Starting is impossible

CHECK CHART CLASSIFIED BY PROBLEM SYMPTOMS

<Vehicles with immobilizer system>

Problem symptoms Check items	Starting		Idling stability			Driving					Stopping	Reference page	
	Will not start	Starting problem	Idling instability (Rough idling)	Incorrect idling speed	Improper idling continuity	Hesitation, sag	Poor acceleration	Stumble	Shock	Surge	Knocking		Run-on (Dieseling)
Power supply and ignition switch-IG	①①												**P.13-54 *P.13-52
Engine control unit power earth	②②												**P.13-57 *P.13-55
Fuel pump	③③	①①			①①	①①	①①						P.13-00 *P.13-58 *P.13-56
Air flow sensor					⑬⑪	⑨⑨		⑤⑤	⑤⑤		④④		*P.13-64 *P.13-62
Intake air temperature sensor			⑤			⑤⑤	⑥⑥				②②		*P.13-69 *P.13-67
Barometric pressure sensor			⑦			⑧⑧	⑧⑧				③③		*P.13-72 *P.13-70
Engine coolant temperature sensor			⑥⑤	①①	⑥⑤	⑦⑦	⑦⑦	④④		③③			*P.13-74 *P.13-72
Throttle position sensor						⑥⑥		③③	④④				*P.13-77 *P.13-75
Idle position switch			③③	②②	④④								*P.13-80 *P.13-78
Cam position sensor	⑤⑤	⑦⑦			⑧⑦				②②				*P.13-82 *P.13-80
Crank angle sensor	⑥⑥	⑧⑧			⑨⑧				③③				*P.13-86 *P.13-84
Ignition switch-ST	④④	③④											*P.13-89 *P.13-87
Vehicle speed sensor					⑥				⑥				*P.13-90 *P.13-88
Power steering fluid pressure switch				③									*P.13-92 *P.13-90
Air conditioner switch and power relay				④									P.13-00 *P.13-94 *P.13-92
Detonation sensor											①①		*P.13-96 *P.13-94
Electrical load switch				⑤									*P.13-98 *P.13-96
Fan motor relay (radiator fan, condenser fan)				⑥	⑪⑩								*P.13-3 *P.13-100-1
Oxygen sensor			⑩										*P.13-100 *P.13-98
Mixture adjusting screw (variable resistor)			⑪										*P.13-106
Injectors	⑧⑧	②②	②②		③③	②②	②②	①①		①①		①	*P.13-109 *P.13-101
Idle speed control servo (stepper motor type)		④⑤	①①	⑦③	②②				⑧⑧				*P.13-116 *P.13-108
Ignition coil and power transistor	⑦⑦				⑩⑨		⑨⑨		①①		⑤⑤		*P.13-121 *P.13-113
Purge control solenoid valve			⑧										*P.13-127 *P.13-119
EGR control solenoid valve						④④		⑥⑥		④④			*P.13-129 *P.13-121
Fuel pressure control valve		⑥	⑨		⑫		④④						*P.13-131 *P.13-123
Waste gate control solenoid valve							⑤⑤						*P.13-134 *P.13-126
Anti-lock braking signal									⑦				*P.13-138 *P.13-130
Fuel pressure		⑤⑥	④④		⑦⑥	③③	③③	②②		②②			*P.13-139 *P.13-131

○ : Warm engine (number inside indicates check order)
 □ : Cold engine (number inside indicates check order)

*1 : Refer to 3000GT '93 Workshop Manual (Pub. No. PWUE9203)
 *2 : Refer to 3000GT '95 Workshop Manual (Pub. No. PWUE9203-3)
 *3 : Refer to 3000GT Workshop Manual (Pub. No. PWUE9119-D)

ON-VEHICLE INSPECTION OF MPI COMPONENTS

FUEL PUMP <Vehicles with immobilizer system>

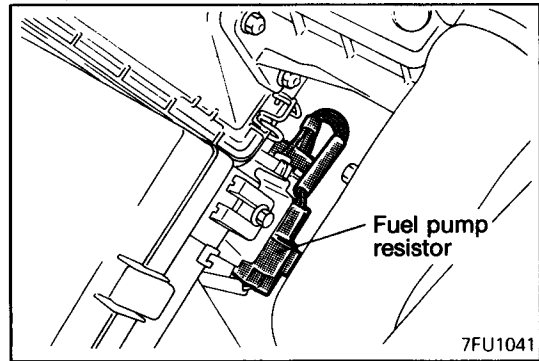
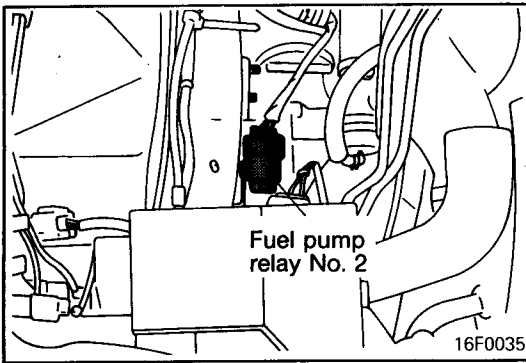
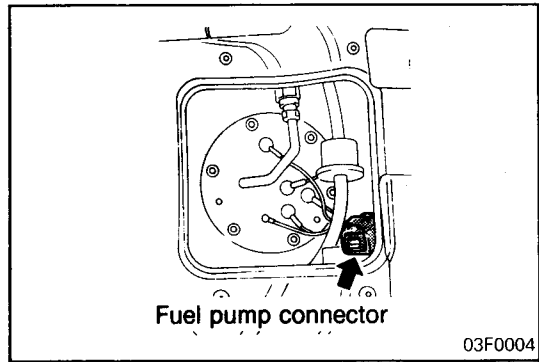
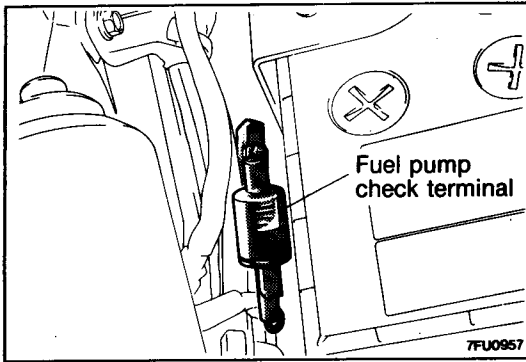

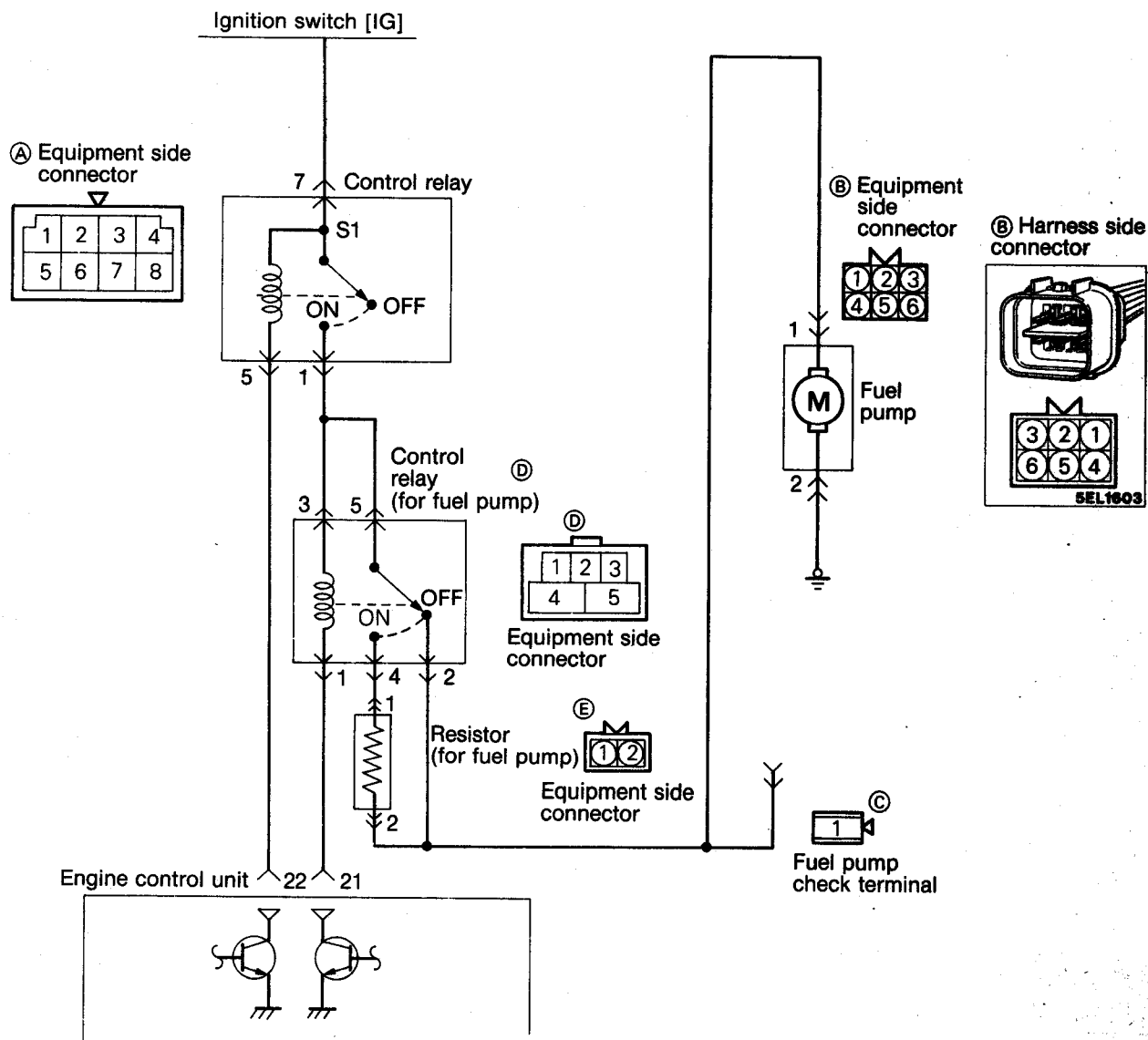

7FU1352

Engine control unit connector

1	2	3	4	5	6	7	8	9	10	11	12	13	14	15	16	17	18	19	20	21	22	23	24	25	26	27	28	29	30	31	32	33	34	35	36	37	38	39	40	41	42	43	44	45	46	47	48	49	50	51	52	53	54	55	56	57	58	59	60	61	62	63	64	65	66	67	68	69	70	71	72	73	74
---	---	---	---	---	---	---	---	---	----	----	----	----	----	----	----	----	----	----	----	----	----	----	----	----	----	----	----	----	----	----	----	----	----	----	----	----	----	----	----	----	----	----	----	----	----	----	----	----	----	----	----	----	----	----	----	----	----	----	----	----	----	----	----	----	----	----	----	----	----	----	----	----	----

9FU0101

HARNESS INSPECTION

<p>1</p> <p>Fuel pump check terminal</p> <p>7FU0953</p>	<p>Check the fuel pump.</p> <ul style="list-style-type: none"> Apply battery voltage to the checking terminal and operate the pump. 	<p>OK → 4</p> <p>OK → 2</p>
---------------------------------------------------------	----------------------------------------------------------------------------------------------------------------------------------------------------	----------------------------------------

<p>2</p> <p>ⓑ Harness side connector</p> <p>7FU0954</p>	<p>Check the earth circuit of the fuel pump.</p> <ul style="list-style-type: none"> Fuel pump connector: Disconnected 	<p>OK → 3</p> <p>OK → Repair the harness. (ⓑ2-Earth)</p>
---------------------------------------------------------	--------------------------------------------------------------------------------------------------------------------------------------	---------------------------------------------------------------------

<p>3</p> <p>ⓑ Harness side connector</p> <p>7FU0955</p>	<p>Check for continuity between the fuel pump and the checking terminal.</p> <ul style="list-style-type: none"> Connector: Disconnected 	<p>OK → 4</p> <p>OK → Repair the harness. (ⓑ1-C1)</p>
---------------------------------------------------------	--------------------------------------------------------------------------------------------------------------------------------------------------------	------------------------------------------------------------------

<p>4</p> <p>ⓓ Harness side connector</p> <p>7FU0960</p>	<p>Check for continuity between the checking terminal and the control relay (for fuel pump), and between the resistor (for fuel pump).</p> <ul style="list-style-type: none"> Control relay (for fuel pump) connector: Disconnected Resistor (for fuel pump) connector: Disconnected Fuel pump connector: Disconnected 	<p>OK → 5</p> <p>OK → Repair the harness. (Ⓒ1-Ⓓ2) (Ⓔ2-E2)</p>
---------------------------------------------------------	---------------------------------------------------------------------------------------------------------------------------------------------------------------------------------------------------------------------------------------------------------------------------------------------------------------------------------------------------------	--------------------------------------------------------------------------

<p>5</p> <p>ⓓ Harness side connector</p> <p>Engine control unit harness side connector</p> <p>7FU0961</p>	<p>Check for an open-circuit, or a short-circuit to earth, between the control relay (for fuel pump) and the engine control unit.</p> <ul style="list-style-type: none"> Control relay (for fuel pump) connector: Disconnected Engine control unit connector: Disconnected 	<p>OK → 6</p> <p>OK → Repair the harness. (Ⓔ1-21)</p>
-----------------------------------------------------------------------------------------------------------	----------------------------------------------------------------------------------------------------------------------------------------------------------------------------------------------------------------------------------------------------------------------------------------------------	------------------------------------------------------------------

6

Ⓔ Harness side connector

Ⓓ Harness side connector

7FU0962

Check for continuity between the control relay (for fuel pump) and the resistor (for fuel pump).

- Control relay (for fuel pump) connector: Disconnected
- Resistor (for fuel pump) connector: Disconnected

OK → **7**

✗ → Repair the harness. (Ⓓ4-Ⓔ1)

7

Ⓐ Harness side connector

9FU0023

Measure the power supply voltage of the control relay.

- Control relay connector: Disconnected

Ignition switch	Voltage (V)
OFF	0-1
ON	SV

OK → **8**

✗ → Repair the harness. (Ignition switch-Ⓐ7) or check the ignition switch.

8

Ⓐ Harness side connector

Engine control unit harness side connector

01A0354

Check for an open-circuit, or a short-circuit to earth between the control relay and the engine control unit.

- Control relay connector: Disconnected
- Engine control unit connector: Disconnected

OK → **9**

✗ → Repair the harness. (Ⓐ5-22)

9

Ⓐ Harness side connector

Ⓓ Harness side connector

7FU1347

Check for continuity between the control relay and the control relay (for fuel pump).

- Control relay connector: Disconnected
- Control relay (for fuel pump) connector: Disconnected

OK → **10**

✗ → Repair the harness. (Ⓐ1-Ⓓ3) (Ⓐ1-Ⓓ5)

10

Ⓑ Harness side connector

Ⓓ Harness side connector

7FU0964

Check for an open-circuit, or a short-circuit to earth, between the control relay (for fuel pump) and the fuel pump.

- Control relay (for fuel pump) connector: Disconnected
- Fuel pump connector: Disconnected

OK → **STOP**

✗ → Repair the harness. (Ⓑ1-Ⓓ2)

AIR CONDITIONER SWITCH AND POWER RELAY

<Vehicles with immobilizer system>

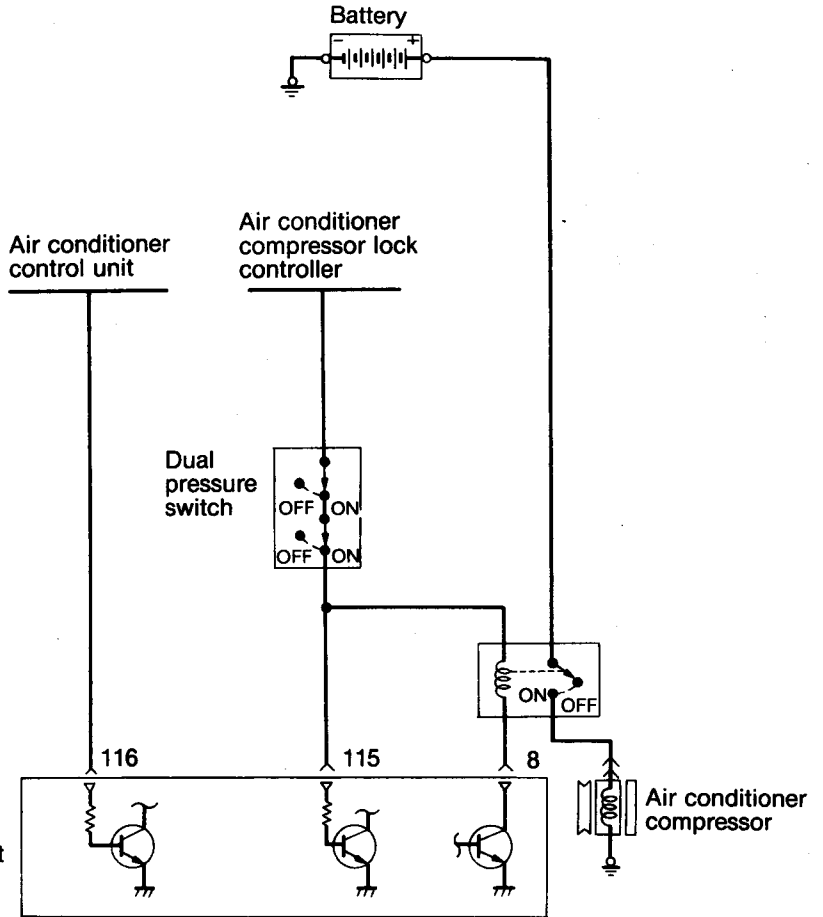
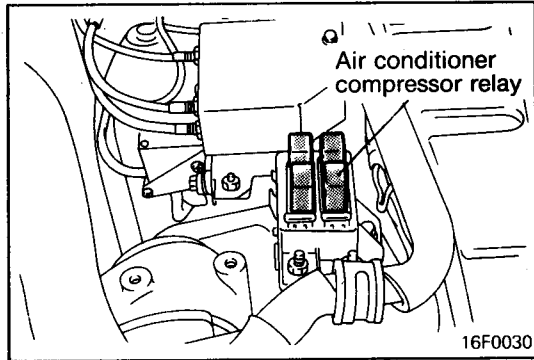
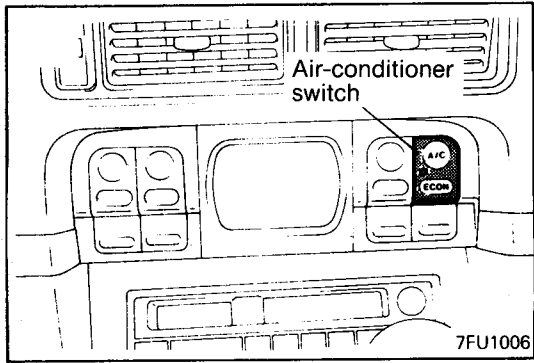

Engine control unit connector

1	2	3	4	5	6	7	8	9	10	11	12	13	14	15	16	17	18	19	20	21	22	23	24	25	26	27	28	29	30	31	32	33	34	35	36	37	38	39	40	41	42	43	44	45	46	47	48	49	50	51	52	53	54	55	56	57	58	59	60	61	62	63	64	65	66	67	68	69	70	71	72	73	74	75	76	77	78	79	80	81	82	83	84	85	86	87	88	89	90	91	92	93	94	95	96	97	98	99	100
---	---	---	---	---	---	---	---	---	----	----	----	----	----	----	----	----	----	----	----	----	----	----	----	----	----	----	----	----	----	----	----	----	----	----	----	----	----	----	----	----	----	----	----	----	----	----	----	----	----	----	----	----	----	----	----	----	----	----	----	----	----	----	----	----	----	----	----	----	----	----	----	----	----	----	----	----	----	----	----	----	----	----	----	----	----	----	----	----	----	----	----	----	----	----	----	----	----	----	-----

7FU0966

9FU0101

HARNESS INSPECTION

1

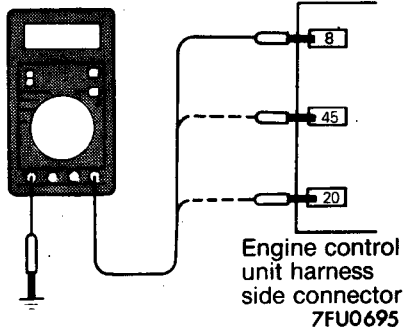

Measure the power supply voltage of the air conditioner circuit.

- Air conditioner switch: ON
- Engine control unit connector: Disconnected
- Ignition switch: ON
- Dual air conditioner switch: ON

Voltage (V)
SV



Check the air conditioner circuit.

ENGINE CONTROL UNIT TERMINAL VOLTAGE CHECK**TERMINAL VOLTAGE CHECK CHART**

<Vehicles with immobilizer system>

Terminal No.	Check point	Check conditions (Engine conditions)	Standard value	Remarks
8	Air conditioner relay	<ul style="list-style-type: none">• Engine: Running at idle• Air conditioner switch: OFF → ON (Air compressor in driven state)	SV or 6V or more for a moment → 0-3V	
22	Control relay (fuel pump)	Ignition switch: ON	SV	
		Engine: Running at idle	0-3V	

NOTES

ENGINE ELECTRICAL

CONTENTS

GENERAL	2	SERVICE ADJUSTMENT PROCEDURES	2
Outline of Change	2	Output Current Test	2
SPECIFICATIONS	2		
Service Specifications	2		

16-2 ENGINE ELECTRICAL – General/Specifications/Service Adjustment Procedures

GENERAL

OUTLINE OF CHANGE

- The nominal output of the alternator has been changed from 110A to 95A in vehicles for Australia and General Export. One of the service specification values has been changed to correspond to this.

SPECIFICATIONS

SERVICE SPECIFICATIONS

ALTERNATOR <Vehicles for Australia and General Export>

Item	Specifications
Limit Output current A	66.5

SERVICE ADJUSTMENT PROCEDURES

OUTPUT CURRENT TEST <Vehicles for Australia and General Export>

Inspection service points are the same as before.

Output current
Limit: 66.5A

GROUP 42 BODY

GENERAL

OUTLINE OF CHANGE

- A power tilt and outer sliding sunroof has been provided as an option in vehicles for Europe.

SPECIFICATIONS

SERVICE SPECIFICATIONS

Items	Standard value
Roof lid sliding resistance N	147 or more
Sunroof motor clutch slippage force N	39 – 49

TROUBLESHOOTING

INSPECTION CHART FOR TROUBLE SYMPTOMS

Trouble symptom	Inspection procedure
Sunroof does not operate within 30 seconds after driver's door is opened.	1
Sunroof does not operate at all.	2

INSPECTION PROCEDURE FOR TROUBLE SYMPTOMS

Inspection Procedure 1

Front sunroof does not operate within 30 seconds after driver's door is opened.	Probable cause
After the driver's door is opened within 30 seconds after the ignition switch is turned off, the sunroof can still be operated for a further 30 seconds. If it is impossible, the driver's door switch or the sunroof control unit may be defective.	<ul style="list-style-type: none"> • Malfunction of door switch (driver's side) • Malfunction of sunroof control unit • Malfunction of wiring harness or connector

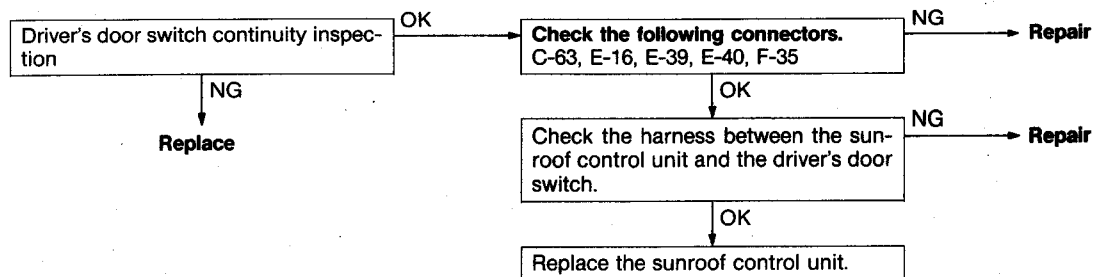

Inspection Procedure 2

Sunroof does not operate at all.	Probable cause
One of the following items may be defective. Sunroof switch Sunroof motor Sunroof control unit Power supply circuit (including the fuse)	<ul style="list-style-type: none"> • Malfunction of sunroof switch • Malfunction of sunroof motor • Malfunction of sunroof control unit • Malfunction of wiring harness or connector

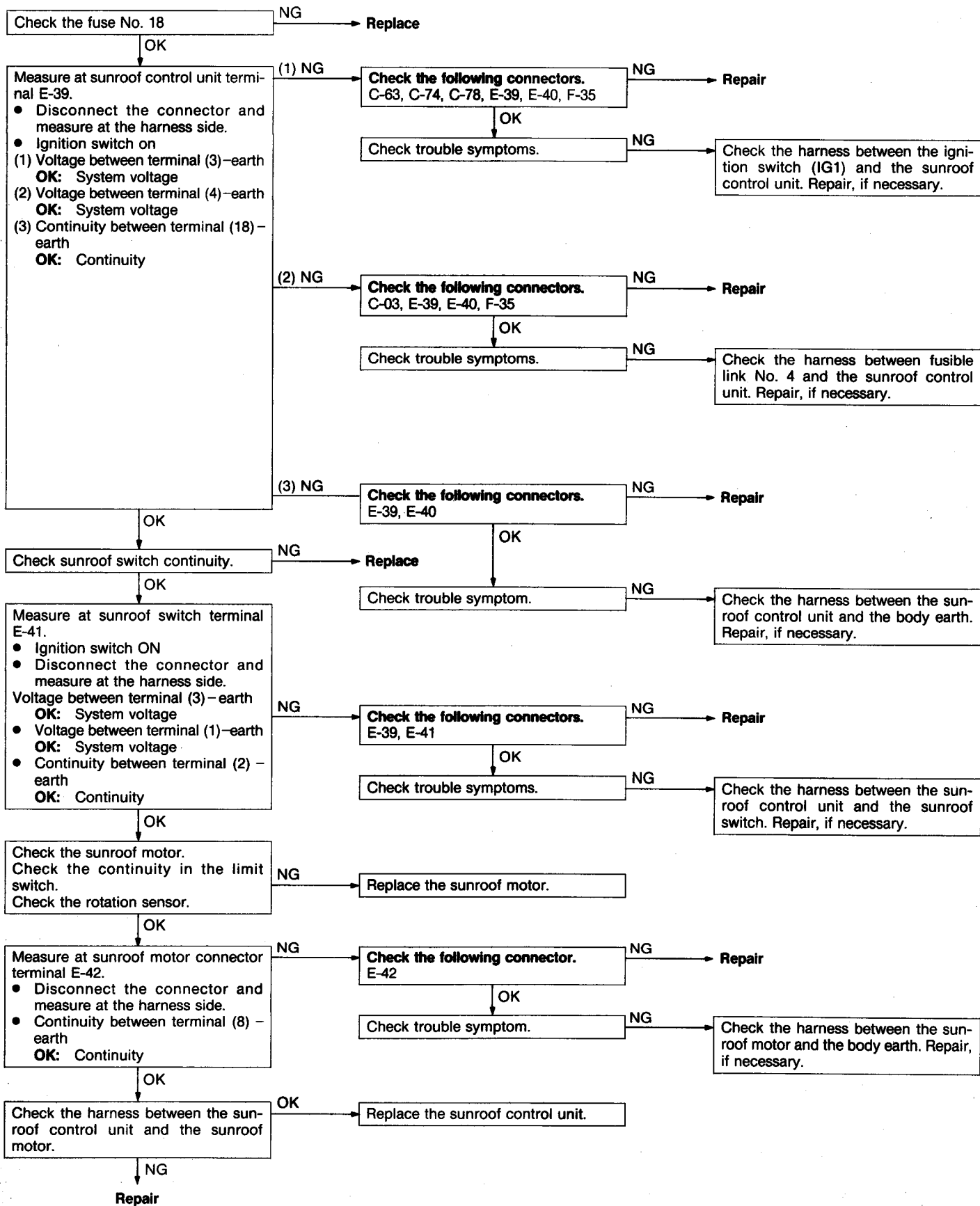

SERVICE ADJUSTMENT PROCEDURES

SUNROOF LEAKAGE INSPECTION

Check if there are any leaks in the sunroof by the following procedure.

- (1) Fully close the roof lid glass.
- (2) Adjust the water pressure so that water comes out of the hose to a height of approximately 50 cm when the hose is held vertically facing upwards.
- (3) Hold the end of the hose about 30 cm above the roof and let the water run onto the weatherstrip for 5 minutes or more.
- (4) While doing this, check if any water leaks through into the passenger compartment from around the roof lid glass.

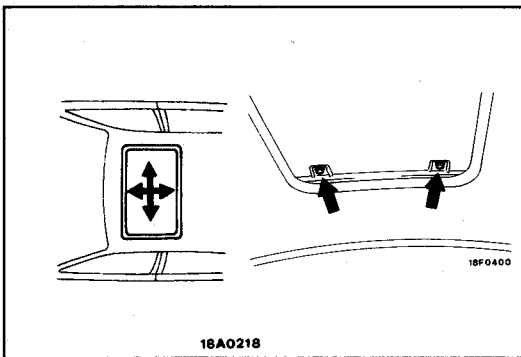
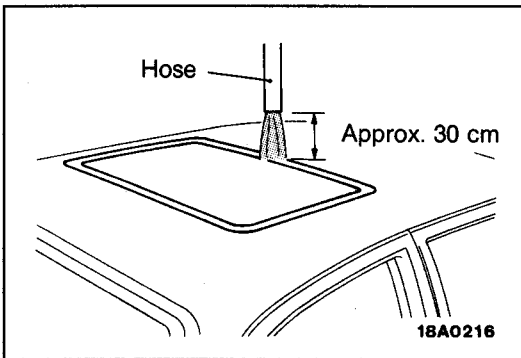
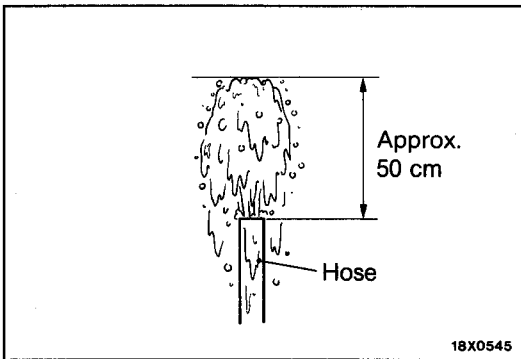

SUNROOF WORKING CHECK

1. Longitudinal and lateral direction adjustment

- (1) Remove the roof lid trim.
- (2) Fully close the roof lid.
- (3) Loosen the four roof lid mounting nuts and adjust the position of the roof lid so that the clearances at the front and rear and at the left and right are the same.

2. Step adjustment

- (1) Remove the headlining.
- (2) Fully close the roof lid.
- (3) Loosen the four adjusting nuts and then adjust the height of the roof lid so that it is flush with the roof.

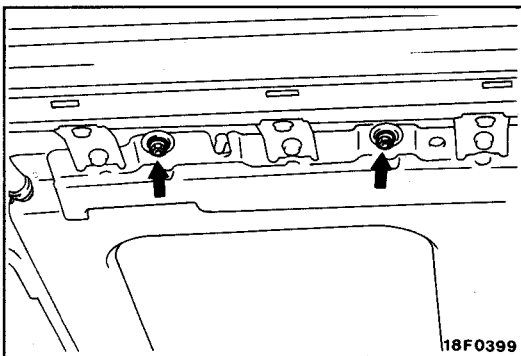

SUNROOF <POWER SLIDING TYPE>**REMOVAL AND INSTALLATION****Post-Installation Operation**

- Sunroof Leakage Inspection
- Sunroof Fit Adjustment

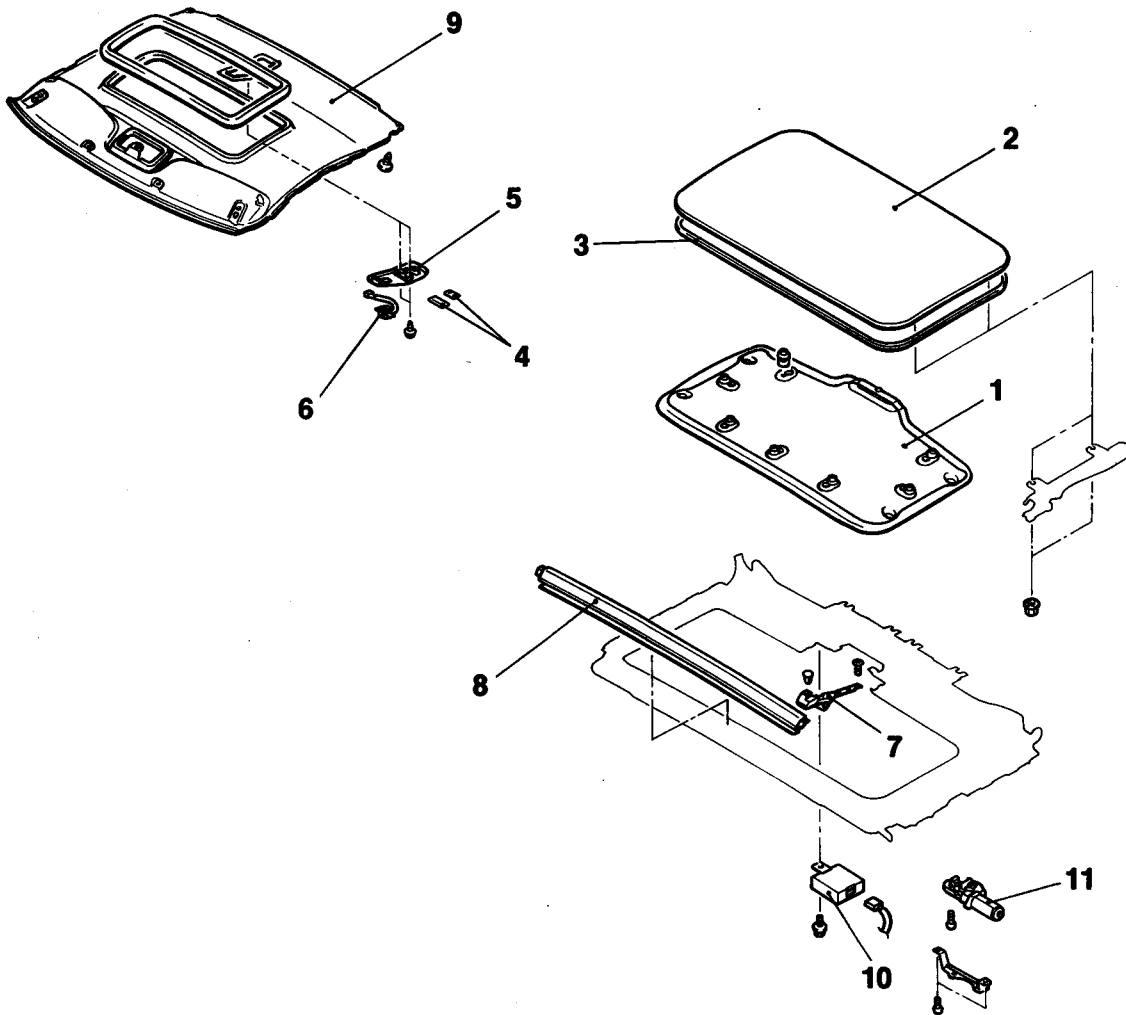

18F0407

**Roof lid removal steps**

1. Roof lid trim
2. Roof lid
3. Roof lid weatherstrip

Sunroof switch removal steps

4. Cover
5. Sunroof switch panel assembly
6. Sunroof switch

Deflector assembly removal steps

- While roof lid is opened fully
7. Link assembly
 8. Deflector assembly

Sunroof control unit removal steps

- Room lamp assembly
4. Cover
 5. Sunroof switch panel assembly
 9. Headlining
 10. Sunroof control unit

Sunroof motor removal steps

- Room lamp assembly
4. Cover
 5. Sunroof switch panel assembly
 9. Headlining
 11. Sunroof motor



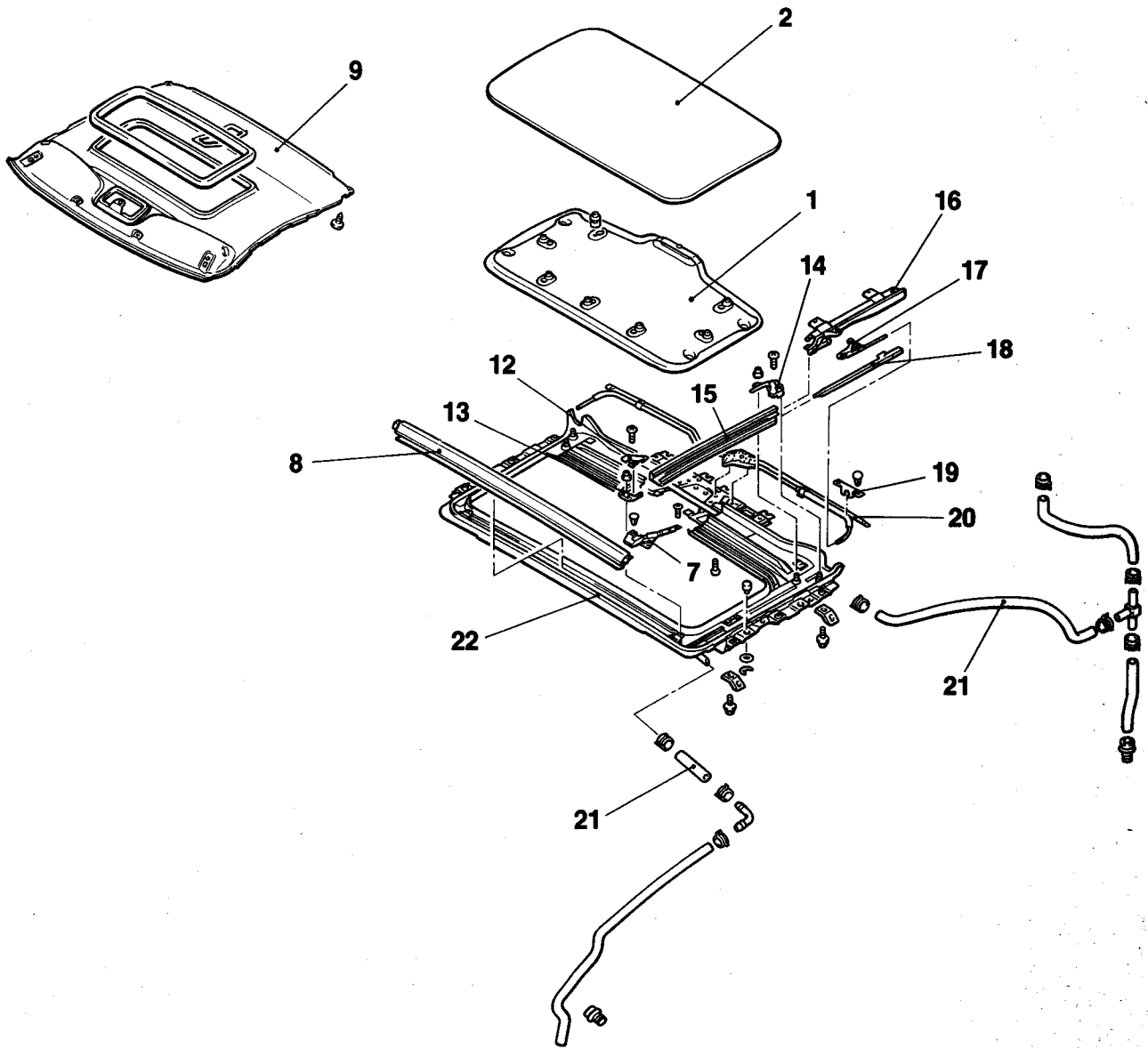

18F0390

Lifter assembly · slider assembly/drive unit assembly removal steps

1. Roof lid trim
2. Roof lid
12. Front corner panel
13. Front holder
14. Rear holder
15. Slid rail
16. Lifter assembly
17. Slider assembly
18. Rear timing
19. Tube cover
20. Drive unit assembly



Frame assembly removal steps

1. Roof lid trim
2. Roof lid
7. Link assembly
8. Deflector assembly
- Room lamp assembly
4. Cover
5. Sunroof switch panel assembly
9. Headlining
21. Drain hose connection
22. Frame assembly

Drain hose removal steps

- Front splash shield
- Rear side trim
- 21. Drain hose

