



Workshop Manual

chassis

SUPPLEMENT

3000GT '98

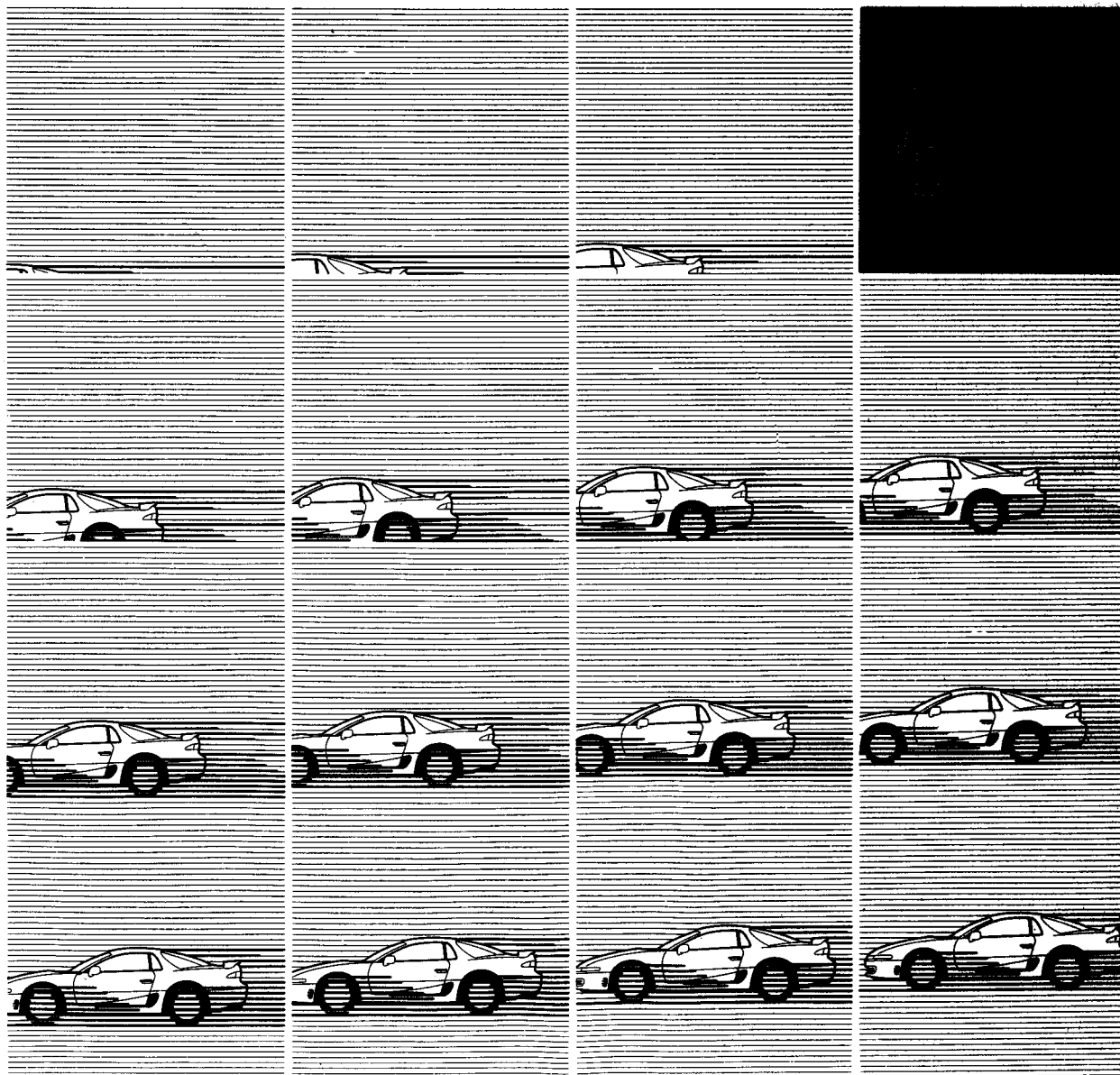

Pub. No. PWUE9119-G

Pub. No. PWUE9203-5

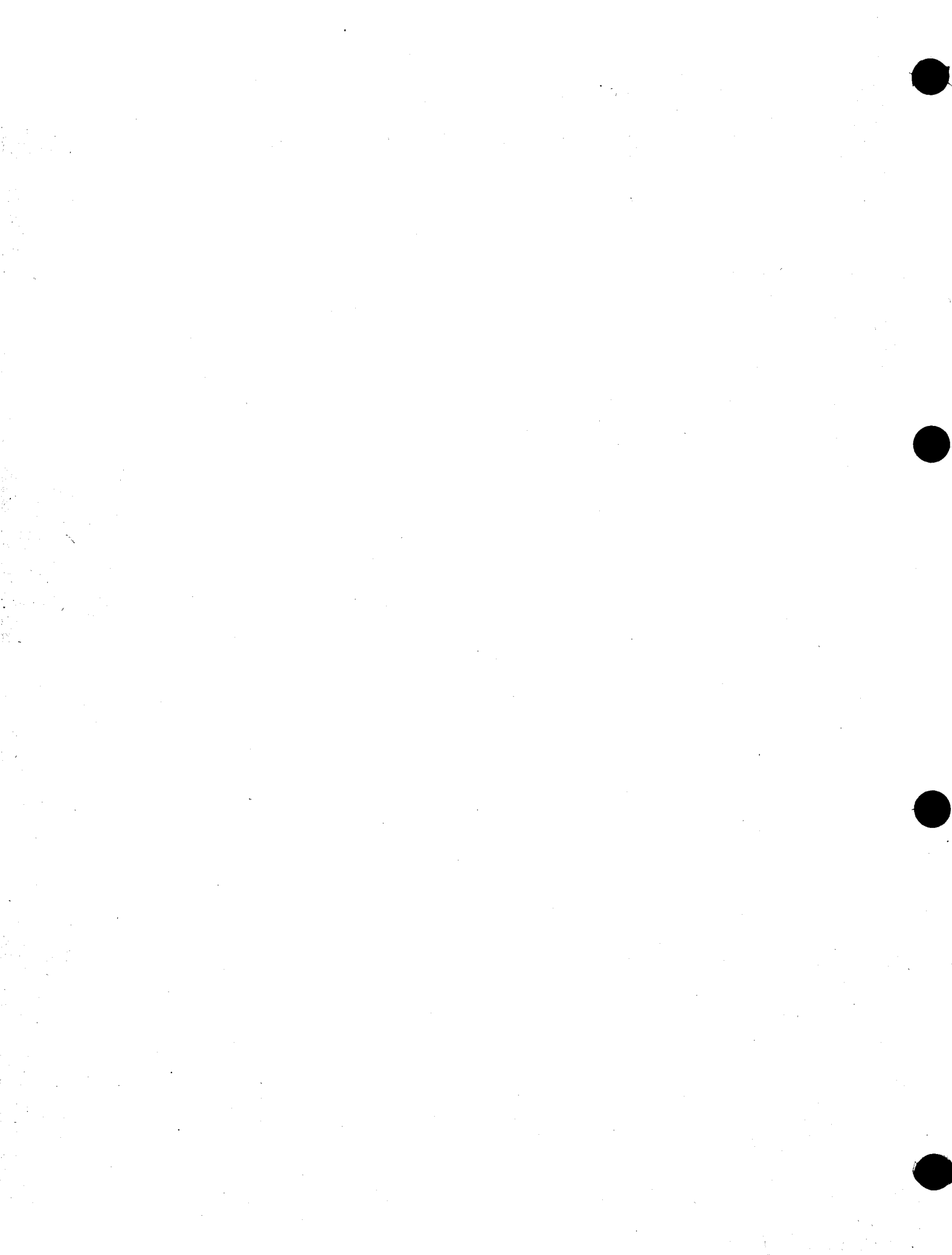

MITSUBISHI 3000GT WORKSHOP MANUAL SUPPLEMENT

General	00
Fuel	13
Engine Electrical	16
Heater, Air conditioner and Ventilation	55

FOREWORD

This Workshop Manual contains procedures for removal, disassembly, inspection, adjustment, reassembly and installation, etc. for service mechanics. Use the manuals indicated on the following page in combination with this manual as required.

All information, illustrations and product descriptions contained in this manual are current as at the time of publication. We, however, reserve the right to make changes at any time without prior notice or obligation.



RELATED PUBLICATIONS

TECHNICAL INFORMATION MANUAL

PYUE9201

WORKSHOP MANUAL

Chassis Group

<Europe>

PWUE9119 (Loose-leaf edition)

PWUE9119-E (Supplement)

PWUE9119-F (Supplement)

<General Export, GCC and
Australia>

PWUE9119 (Loose-leaf edition)

PWUE9203 (Basic)

PWUE9203-1 (Supplement)

PWUE9203-2 (Supplement)

PWUE9203-3 (Supplement)

PWUE9203-4 (Supplement)

Engine Group

PWEE□□□□ (Loose-leaf edition)

ELECTRICAL WIRING

<Europe>

PHUE9201 (Loose-leaf edition)

PHUE9201-D (Supplement)

PHUE9201-E (Supplement)

PHUE9201-F (Supplement)

<General Export, GCC and
Australia>

PHUE9406 (Basic)

PHUE9406-1 (Supplement)

PHUE9406-2 (Supplement)

PARTS CATALOGUE

<Europe>

B608K408A□

<General Export, GCC>

B808K408A□

<Australia>

BFA8K408A□

WARNINGS REGARDING OF SUPPLEMENTAL RESTRAINT SYSTEM (SRS) EQUIPPED VEHICLES

WARNING!

- (1) Improper service or maintenance of any component of the SRS, or any SRS-related component, can lead to personal injury or death to service personnel (from inadvertent firing of the air bag) or to the driver (from rendering the SRS inoperative).
- (2) If it is possible that the SRS components are subjected to heat over 93°C (200°F) in baking or in drying after painting, remove the SRS components (air bag module, SRS-ECU) beforehand.
- (3) Service or maintenance of any SRS component or SRS-related component must be performed only at an authorized MITSUBISHI dealer.
- (4) MITSUBISHI dealer personnel must thoroughly review this manual, and especially its GROUP 52B – Supplemental Restraint System (SRS), before beginning any service or maintenance of any component of the SRS or any SRS-related component.

GENERAL 00

GENERAL

VEHICLE IDENTIFICATION

MODEL

VEHICLES FOR EUROPE

Model code	Engine model	Transmission model	Fuel supply system
Z16AMJGFL6	6G72 (2,972 ml)	W6MG1	MPI
Z16AMJGFR6			

VEHICLES FOR GENERAL EXPORT

Model code	Engine model	Transmission model	Fuel supply system
Z16AMNGFL	6G72 (2,972 ml)	W5MG1	MPI
Z16AMNGFR			

VEHICLES FOR GCC

Model code	Engine model	Transmission model	Fuel supply system
Z16AMNGFLW	6G72 (2,972 ml)	W5MG1	MPI

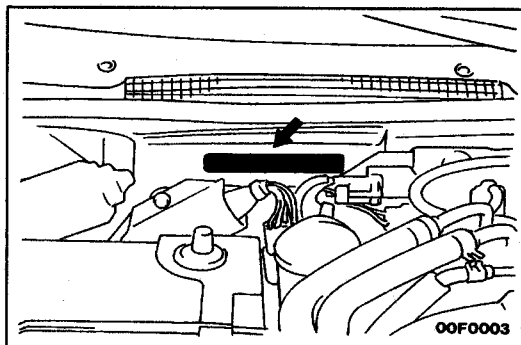

VEHICLES FOR AUSTRALIA

Model code	Engine model	Transmission model	Fuel supply system
Z16AMNGFR8	6G72 (2,972 ml)	W5MG1	MPI



CHASSIS NUMBER

The chassis number is stamped on the toeboard inside the engine compartment.



J **M** **B** **M** **N** **Z16** **A** **W** **Y** **000001**

1 2 3 4 5 6 7 8 9 10

V0207AA

- | | |
|---|--|
| <p>1. Asia</p> <p>2. Japan</p> <p>3. MITSUBISHI
 A - For Europe, right hand drive
 B - For Europe, left hand drive
 F - For Australia, right hand drive
 Y - For General Export or GCC</p> <p>4. Body style
 M - 2-door hatchback</p> <p>5. Transmission type
 N - 5-speed manual transmission
 J - 6-speed manual transmission</p> | <p>6. Development order
 Z16 - 2,972 ml (Full time 4WD)</p> <p>7. Sort
 A - Passenger car</p> <p>8. Model year
 W - 1998</p> <p>9. Plant
 Y - Ohe Motor Vehicle Works</p> <p>10. Serial number</p> |
|---|--|

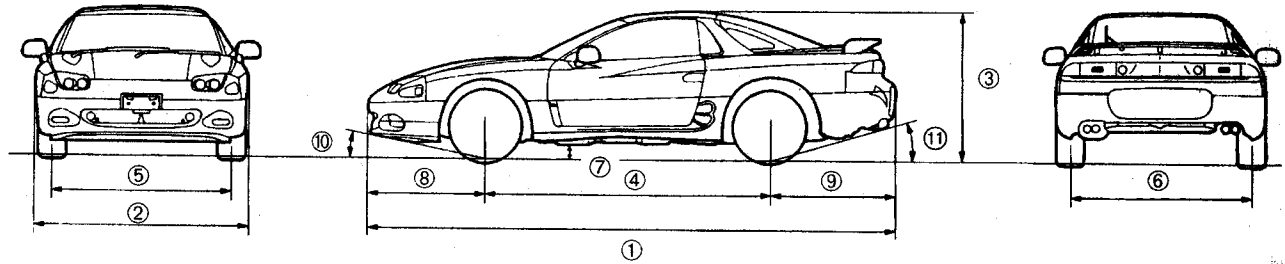
MAJOR SPECIFICATIONS



00F0664

Dimensions

Items		Z16AMJGFL6 Z16AMJGFL6	Z16AMNGFL Z16AMNGFR Z16AMNGFLW	Z16AMNGFR8
Overall length mm (in.)	①	4,570 (1799.9)	4,570 (1799.9)	4,570 (1799.9)
Overall width mm (in.)	②	1,840 (72.4)	1,840 (72.4)	1,840 (72.4)
Overall height (unladen) mm (in.)	③	1,285 (50.6)	1,285 (50.6)	1,285 (50.6)
Wheelbase mm (in.)	④	2,470 (97.2)	2,470 (97.2)	2,470 (97.2)
Track-front mm (in.)	⑤	1,560 (62.2)	1,560 (62.2)	1,560 (62.2)
Track-rear mm (in.)	⑥	1,580 (62.2)	1,580 (62.2)	1,580 (62.2)
Ground clearance (unladen) mm (in.)	⑦	140 (5.5)	140 (5.5)	140 (5.5)
Overhang-front mm (in.)	⑧	1,030 (40.6)	1,030 (40.6)	1,030 (40.6)
Overhang-rear mm (in.)	⑨	1,070 (42.1)	1,070 (42.1)	1,070 (42.1)
Angle of approach	⑩	11.2°	11.2°	11.2°
Angle of departure depress	⑪	11.7°	11.7°	11.7°

Weight

Items		Z16AMJGFL6 Z16AMJGFR6	Z16AMNGFL Z16AMNGFR Z16AMNGFLW	Z16AMNGFR8
Kerb weight kg (lbs.)		1,730 (3,858)	1,695 (3,737)	1,700 (3,748)
Gross vehicles weight kg (lbs.)		2,120 (4,674)	2,075 (4,575)	2,080 (4,586)
Max. axle weight kg (lbs.)	front	1,150 (2,535)	1,150 (2,535)	1,150 (2,535)
	rear	1,020 (2,249)	1,020 (2,249)	1,020 (2,249)

Seating capacity

Items	Z16AMJGFL6 Z16AMJGFR6	Z16AMNGFL Z16AMNGFR Z16AMNGFLW	Z16AMNGFR8
Seating capacity	4	4	4

Engine

Items	Z16AMJGFL6 Z16AMJGFR6	Z16AMNGGFL Z16AMNGFR Z16AMNGFLW	Z16AMNGFR8
Model	6G72	6G72	6G72
Total displacement mℓ	2,972	2,972	2,972

Transmission

Items	Z16AMJGFL6 Z16AMJGFR6	Z16AMNGFL Z16AMNGFR Z16AMNGFLW	Z16AMNGFR8
Model	W6MG1	W5MG1	W5MG1
Type	6-speed manual	5-speed manual	5-speed manual

FUEL

CONTENTS

GENERAL	2
Outline of Change	2
ON-VEHICLE INSPECTION OF MPI COMPONENTS	2
Mixture Adjusting Screw (variable resistor) <Vehicles for General Export and GCC>	2

GENERAL

OUTLINE OF CHANGE

- The connector for the mixture adjusting screw (variable resistor) has been changed. The following maintenance service points which are different from previous vehicles have been established to correspond to this.

ON-VEHICLE INSPECTION OF MPI COMPONENTS

MIXTURE ADJUSTING SCREW (Variable Resistor) <Vehicles for General Export and GCC>

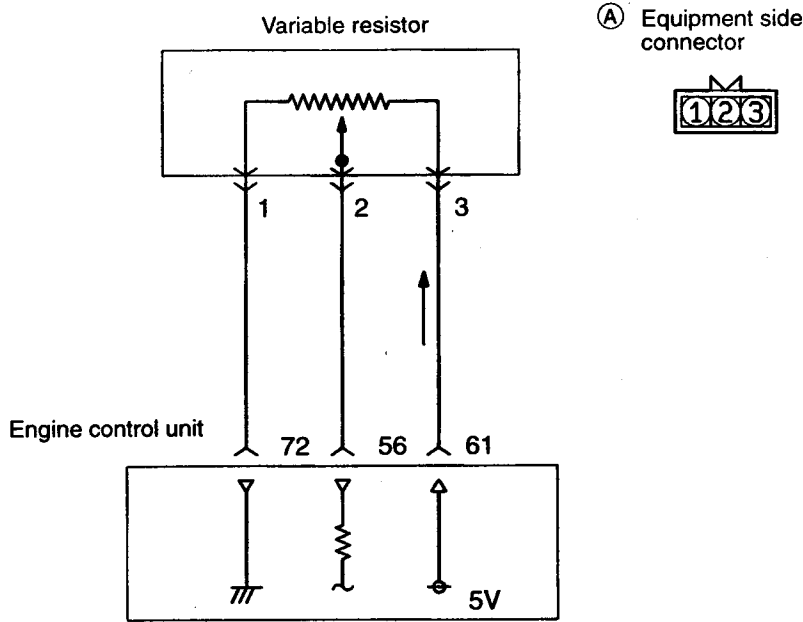

7FU2073

HARNESS INSPECTION

<div style="border: 1px solid black; padding: 5px; width: 40px; text-align: center; font-weight: bold; font-size: 24px;">1</div> <p>(A) Harness side connector</p> <p style="text-align: right;">7FU2074</p>	<p>Measure the power supply voltage of the variable resistor.</p> <ul style="list-style-type: none"> • Connector: Disconnected • Ignition switch: ON <table border="1" style="width: 100%; margin-top: 10px;"> <tr> <td style="text-align: center;">Voltage (V)</td> </tr> <tr> <td style="text-align: center;">4.8 – 5.2</td> </tr> </table>	Voltage (V)	4.8 – 5.2	<div style="display: flex; flex-direction: column; align-items: center;"> <div style="display: flex; align-items: center; margin-bottom: 20px;"> <div style="font-size: 24px; font-weight: bold; border: 1px solid black; border-radius: 50%; padding: 10px; margin-right: 10px;">OK</div> <div style="font-size: 24px;">→</div> <div style="border: 1px solid black; padding: 5px; width: 40px; text-align: center; font-weight: bold; font-size: 24px;">2</div> </div> <div style="display: flex; align-items: center;"> <div style="font-size: 24px; font-weight: bold; border: 1px solid black; border-radius: 50%; padding: 10px; margin-right: 10px;">OK</div> <div style="font-size: 24px;">→</div> <div style="padding-left: 10px;"> <p>Repair the harness.</p> <p>(A) [3] – [61]</p> </div> </div> </div>
Voltage (V)				
4.8 – 5.2				

<p>2</p> <p>7FU2075</p>	<p>Check for continuity of the earth circuit.</p> <ul style="list-style-type: none"> • Connector: Disconnected 	<p>OK → 3</p> <p>OK → Repair the harness. (A 1 - 72)</p>
--------------------------------	---	---

<p>3</p> <p>7FU2076</p>	<p>Check for an open-circuit, or a shortcircuit to earth between the engine control unit and the variable resistor.</p> <ul style="list-style-type: none"> • Variable resistor connector: Disconnected • Engine control unit connector: Disconnected 	<p>OK → STOP</p> <p>OK → Repair the harness. (A 2 - 56)</p>
--------------------------------	--	--

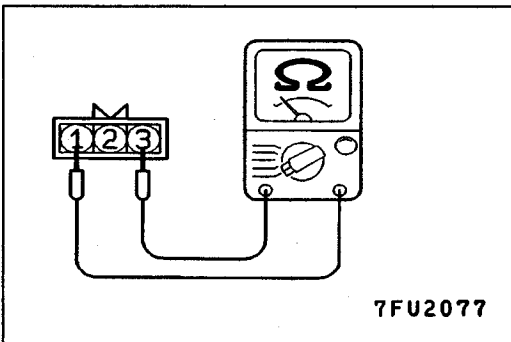

SENSOR INSPECTION

- (1) Disconnect the variable resistor connector.
- (2) Use a circuit tester to measure the resistance between terminal ① and terminal ③ of the variable resistor connector.

Standard value: 4 – 6 kΩ

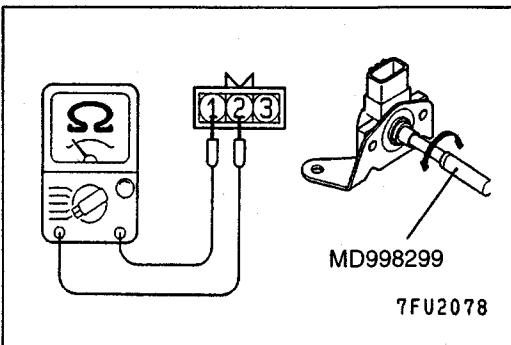

- (3) Next, connect the circuit tester between terminal ① and terminal ②.
- (4) Check if the resistance changes smoothly when the adjusting screw is rotated by the special tool (MAS driver).
- (5) Inspect the body for cracks or other damage.
- (6) If any defect is found, replace the variable resistor as an assembly.

**GROUP 16
ENGINE ELECTRICAL**

GENERAL

OUTLINE OF CHANGE

- The nominal output for the alternator has been changed to 110 A in vehicles for General Export and Australia. The alternator output current specifications have been changed as follows to correspond to this.

SPECIFICATIONS

SERVICE SPECIFICATIONS

ALTERNATOR <Vehicles for General Export and Australia>

Item	Specifications
Limit Output current A	77A

SERVICE ADJUSTMENT PROCEDURES

OUTPUT CURRENT TEST <Vehicles for General Export and Australia>

Inspection service points are the same as before.

Output current

Limit: 77A

HEATER, AIR CONDITIONER AND VENTILATION

CONTENTS

GENERAL	2	DAMPER CONTROL MOTOR	
Outline of Changes	2	ASSEMBLY	28
TROUBLESHOOTING	2	COMPRESSOR	29
AIR CONDITIONER CONTROL		CONDENSER AND CONDENSER FAN	
PANEL AND ECU ASSEMBLY	27	MOTOR	29



GENERAL

OUTLINE OF CHANGES

An air conditioning control panel and ECU assembly which integrates the air conditioning control panel and the ECU has been adopted. The following items have been changed to correspond to this.

- Troubleshooting
- Removal and installation service points for the air conditioning control panel and ECU assembly
- Removal and installation service points for the damper control motor assembly
- Inspection service points for operation of the thermostat and the compressor's magnetic clutch
- Inspection service points for the revolution pickup sensor
- Inspection service points for the condenser fan motor

TROUBLESHOOTING

INSPECTION CHART FOR DIAGNOSIS CODES

Code No.	Diagnosis item	Reference page
11	Interior temperature sensor system (open circuit)	55-3
12	Interior temperature sensor system (short circuit)	55-3
13	Air inlet sensor system (open circuit)	55-4
14	Air inlet sensor system (short circuit)	55-4
15	Engine coolant temperature sensor system (open circuit)	55-5
16	Engine coolant temperature sensor system (short circuit)	55-5
21	Air thermo sensor system (open circuit)	55-6
22	Air thermo sensor system (short circuit)	55-6
31	Potentiometer system of blend air damper motor assembly	55-7
32	Potentiometer system of mode selection damper motor assembly	55-8
41	Drive system of air mix damper motor assembly	55-9
42	Drive system of mode selection damper motor assembly	55-9

INSPECTION PROCEDURES FOR DIAGNOSIS CODES

Code No.11 or 12 Interior temperature sensor system	Probable cause
This diagnosis code is output if the interior temperature sensor is defective.	<ul style="list-style-type: none"> ● Malfunction of connector ● Malfunction of harness ● Malfunction of interior temperature sensor ● Malfunction of the A/C-ECU

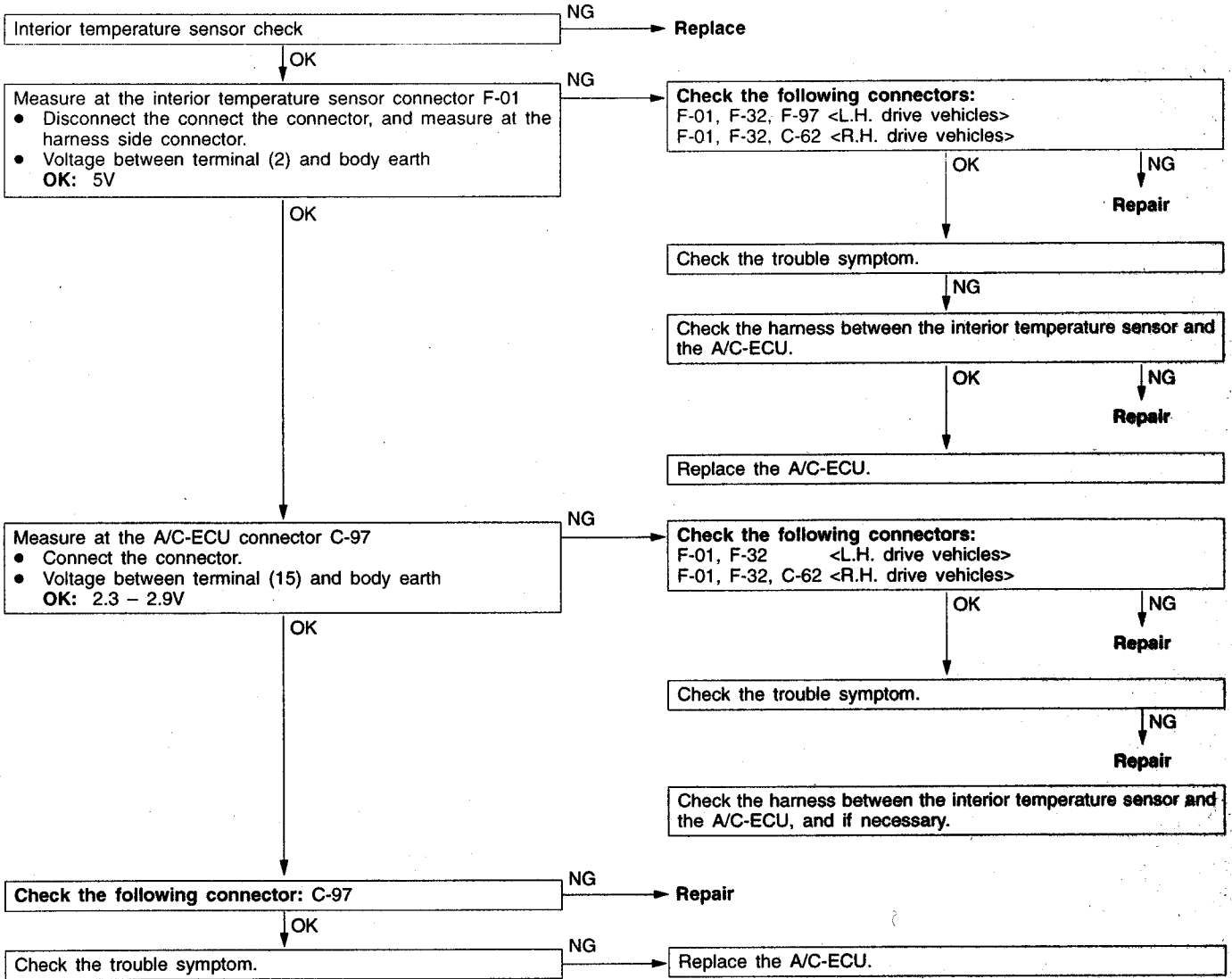

Code No.13 Air inlet sensor system (open circuit)	Probable cause
This diagnosis code is output if there is a defective connector connection, or if there is an open circuit in the harness.	<ul style="list-style-type: none"> ● Malfunction of connector ● Malfunction of harness ● Malfunction of the air inlet sensor ● Malfunction of the A/C-ECU

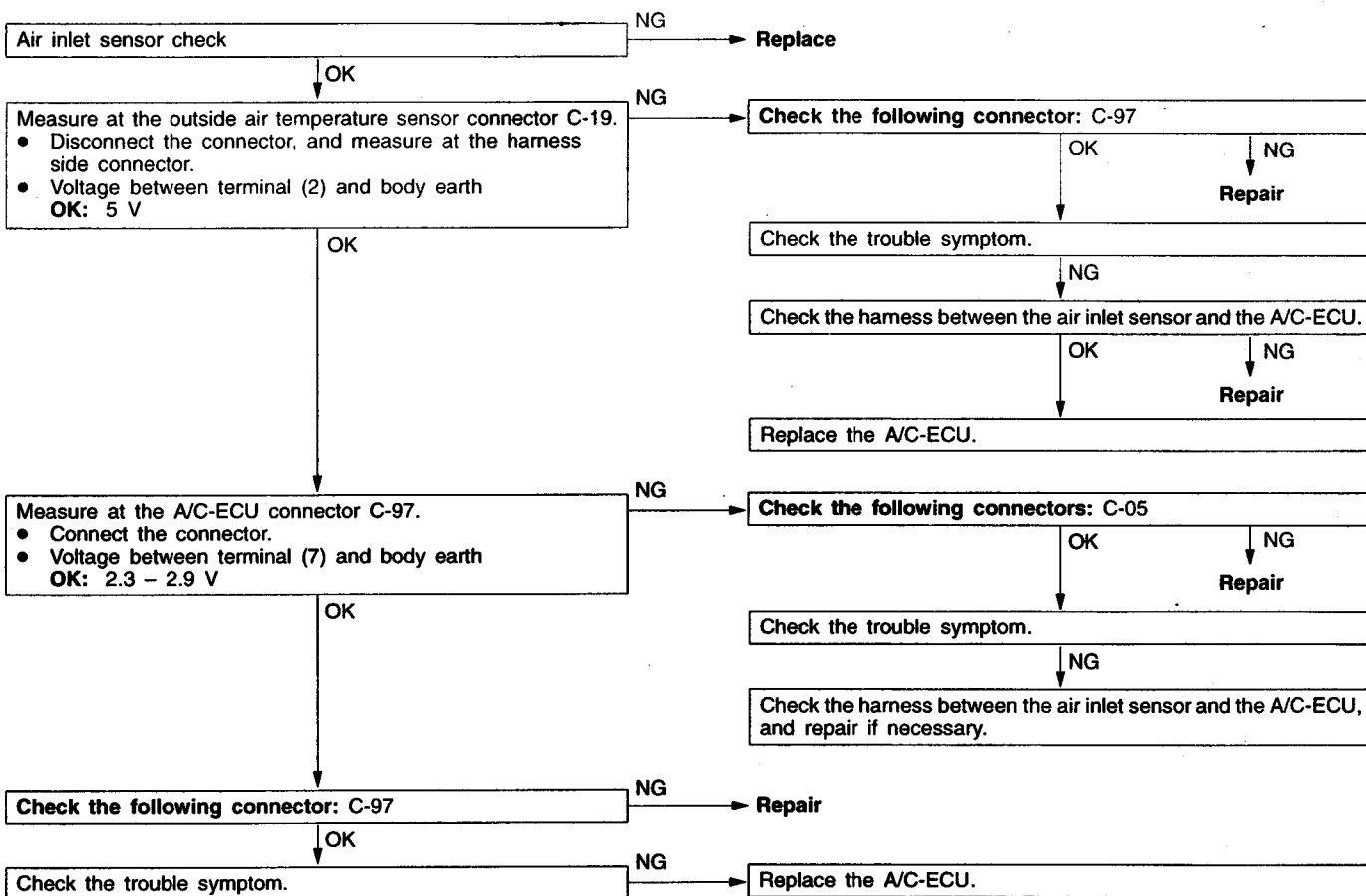

Code No.14 Air inlet sensor system (short circuit)	Probable cause
This diagnosis code is output if there is a short circuit in the air inlet sensor input circuit.	<ul style="list-style-type: none"> ● Malfunction of harness ● Malfunction of connector ● Malfunction of the air inlet sensor ● Malfunction of the A/C-ECU

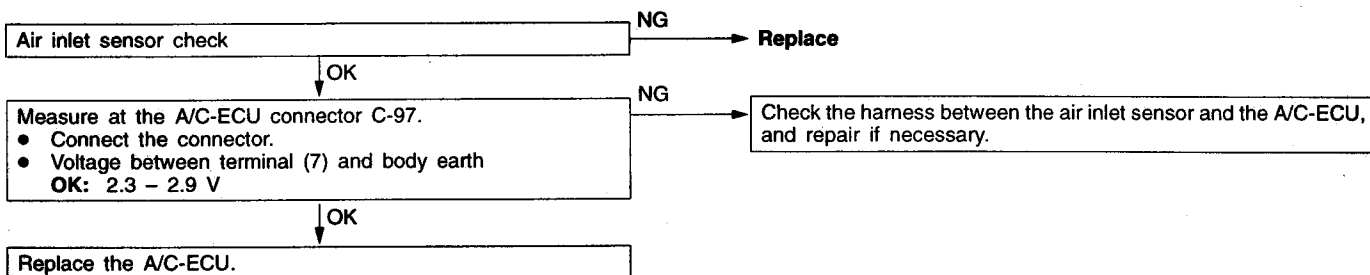

Code No.15 Engine coolant temperature sensor system (open circuit)	Probable cause
This diagnosis code is output if there is a defective connector connection, or if there is an open circuit in the harness.	<ul style="list-style-type: none"> ● Malfunction of connector ● Malfunction of harness ● Malfunction of the engine coolant temperature sensor ● Malfunction of the A/C-ECU

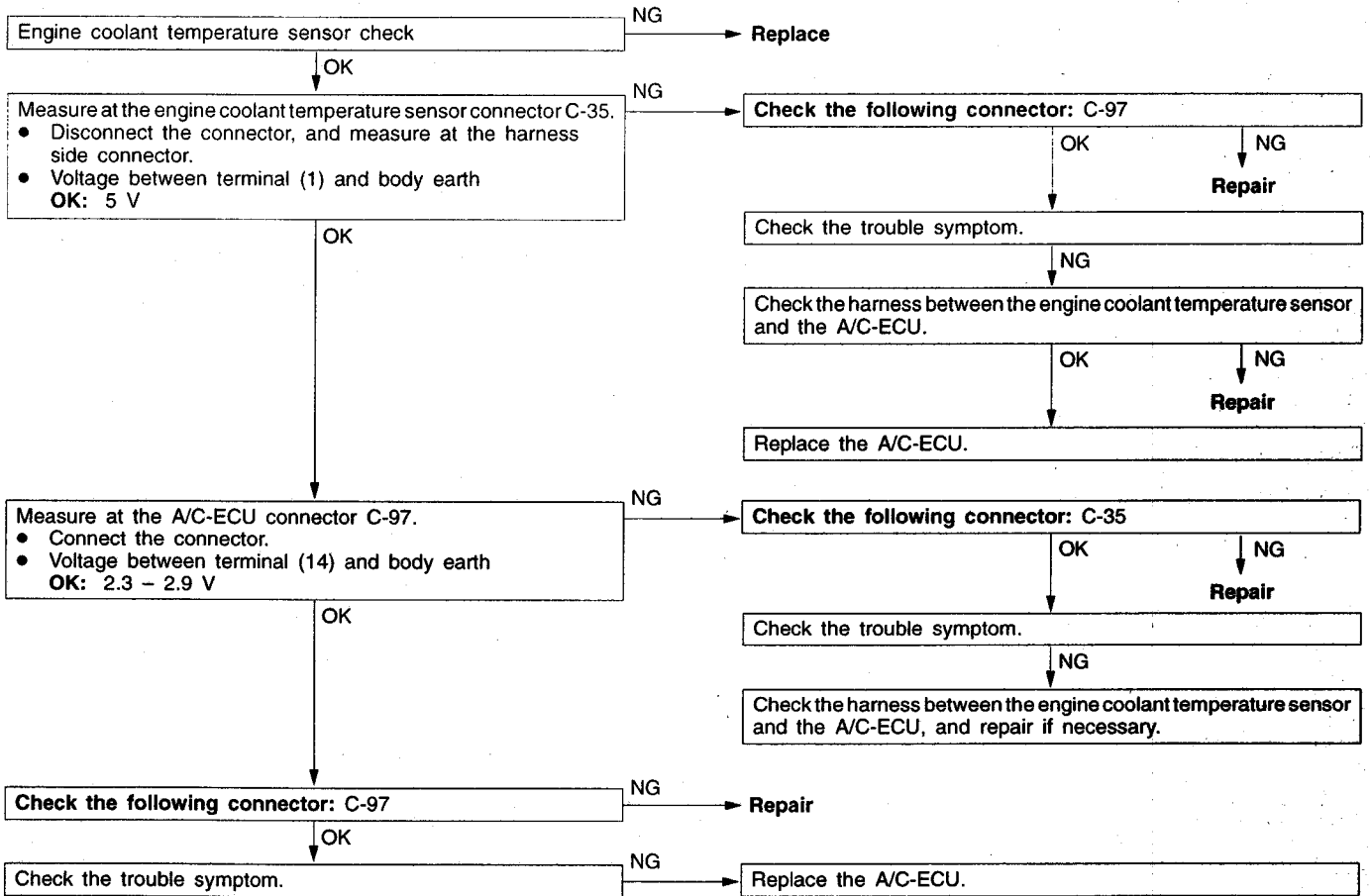

Code No.16 Engine coolant temperature sensor system (short circuit)	Probable cause
This diagnosis code is output if there is a short circuit in the engine coolant temperature sensor input circuit.	<ul style="list-style-type: none"> ● Malfunction of harness ● Malfunction of connector ● Malfunction of the engine coolant temperature sensor ● Malfunction of the A/C-ECU

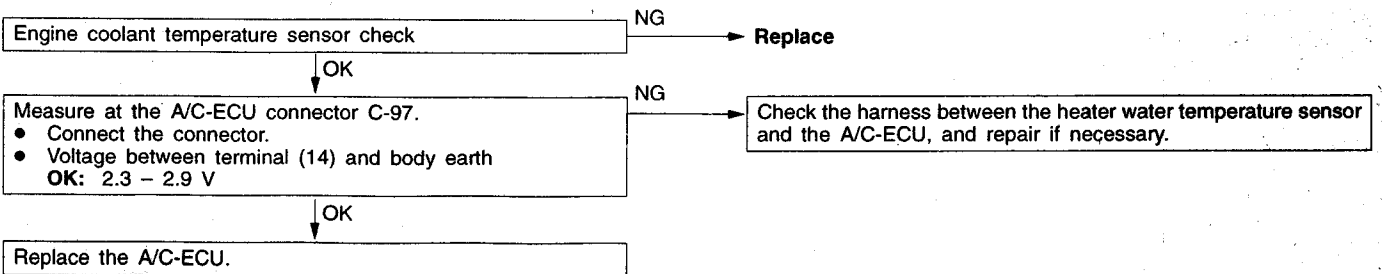

Code No.21 Air thermo sensor system (open circuit)	Probable cause
This diagnosis code is output if there is a defective connector connection, or if there is an open circuit in the harness.	<ul style="list-style-type: none"> ● Malfunction of connector ● Malfunction of harness ● Malfunction of the air thermo sensor ● Malfunction of the A/C-ECU

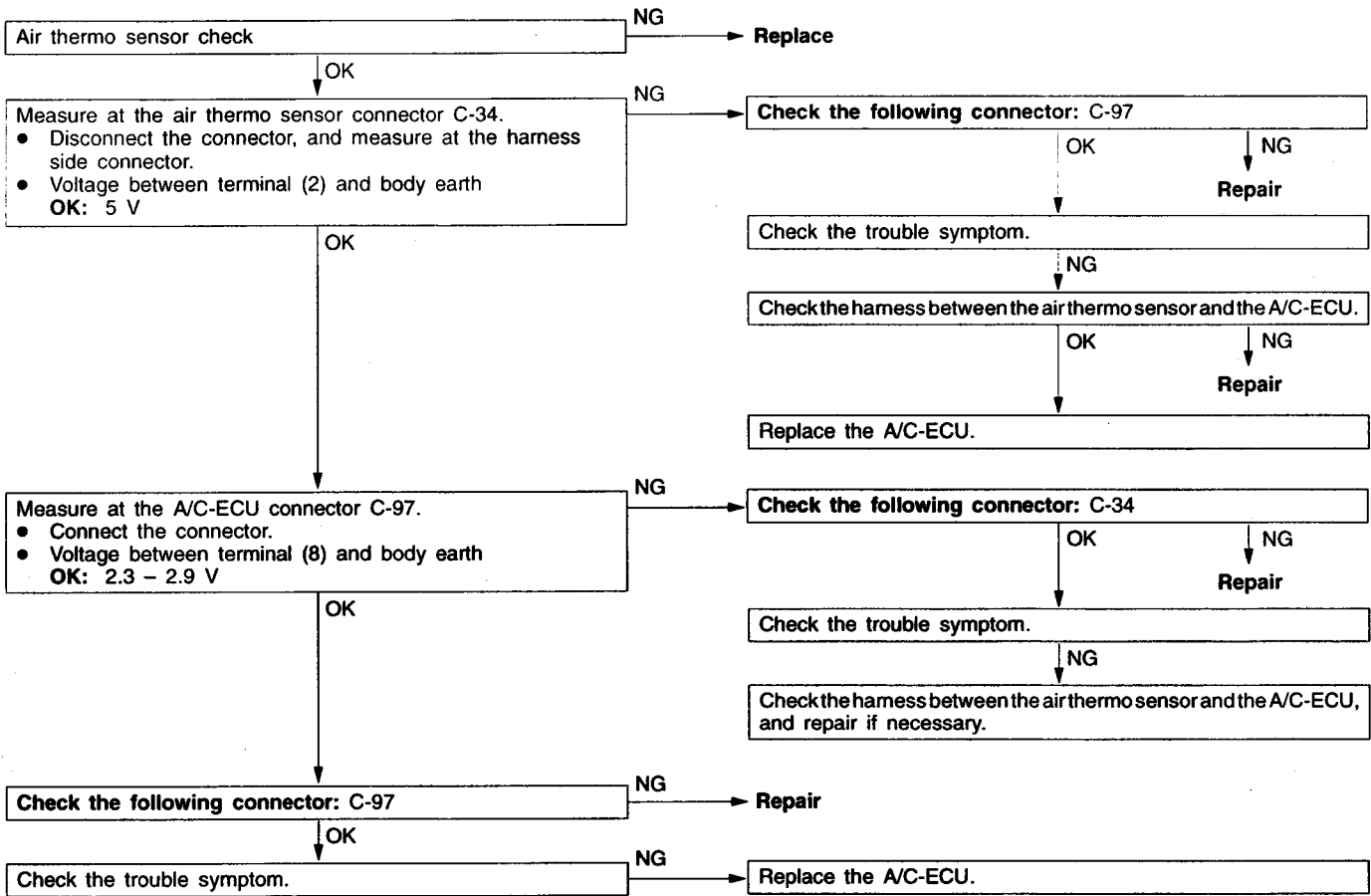

Code No.22 Air thermo sensor system (short circuit)	Probable cause
This diagnosis code is output if there is a short circuit in the air thermo sensor input circuit.	<ul style="list-style-type: none"> ● Malfunction of harness ● Malfunction of connector ● Malfunction of the air thermo sensor ● Malfunction of the A/C-ECU

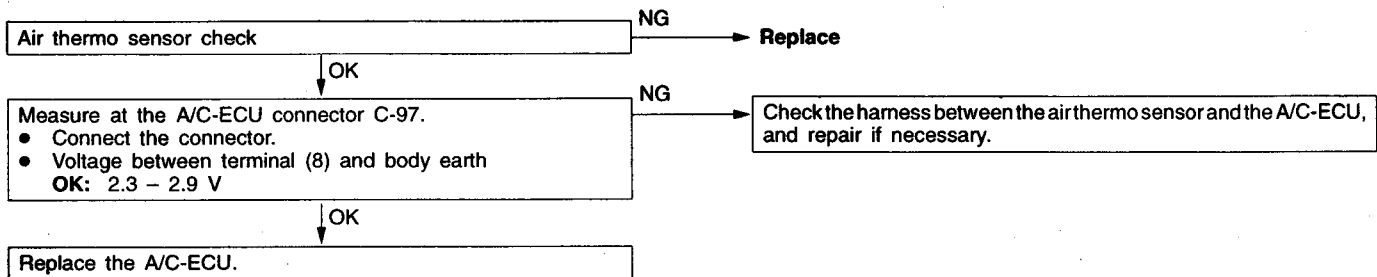

Code No.31 Potentiometer system of blend air damper motor assembly	Probable cause
This diagnosis code is output if there is an open or short circuit in the potentiometer input circuit, or if there is an open circuit in the power circuit or earth circuit.	<ul style="list-style-type: none"> ● Malfunction of the blend air damper motor assembly ● Malfunction of connector ● Malfunction of harness ● Malfunction of the A/C-ECU

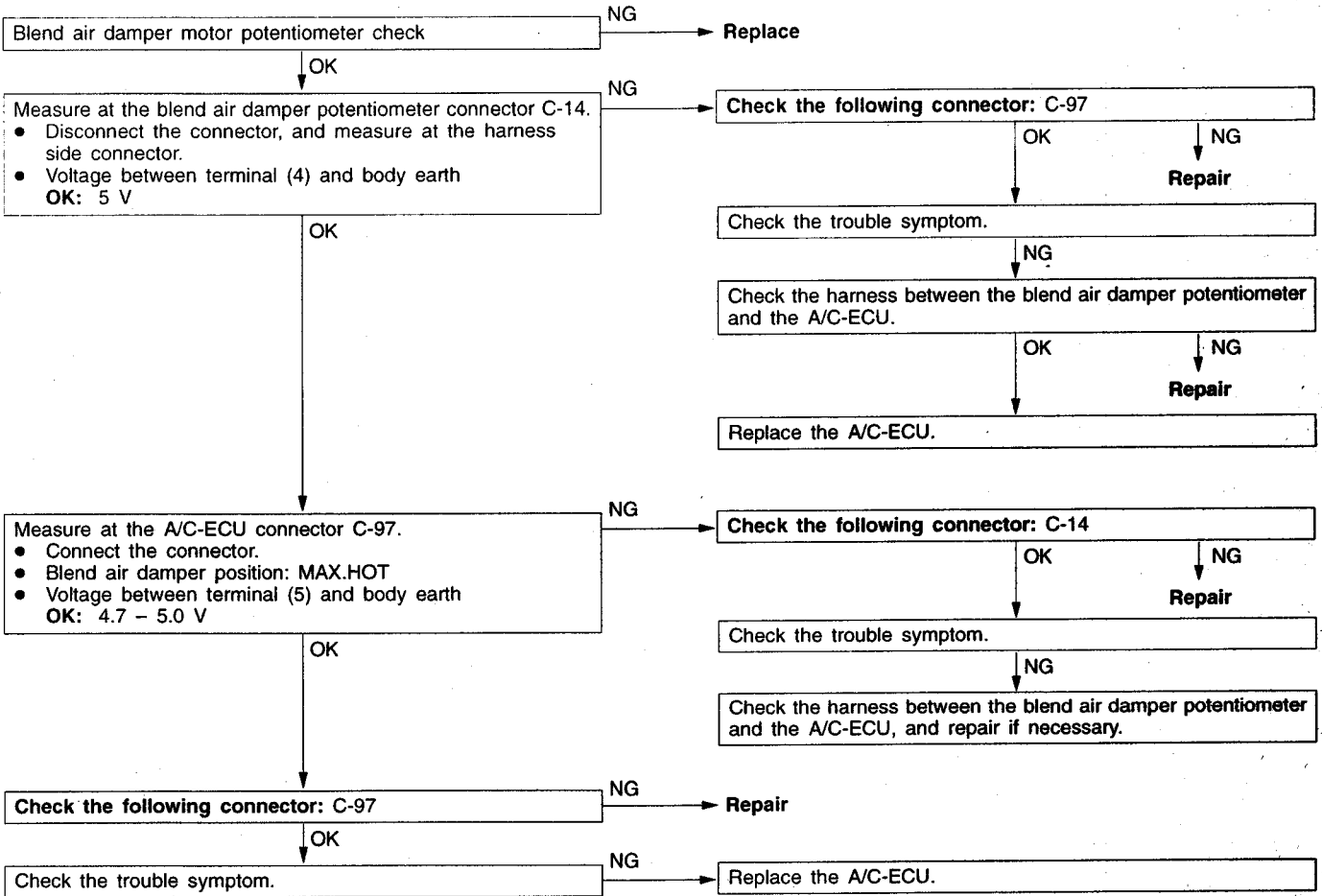

Code No.32 Potentiometer system of mode selection damper motor assembly	Probable cause
This diagnosis code is output if there is an open or short circuit in the potentiometer input circuit, or if there is an open circuit in the power circuit or earth circuit.	<ul style="list-style-type: none"> • Malfunction of the mode selection damper motor assembly • Malfunction of connector • Malfunction of the A/C-ECU • Malfunction of harness

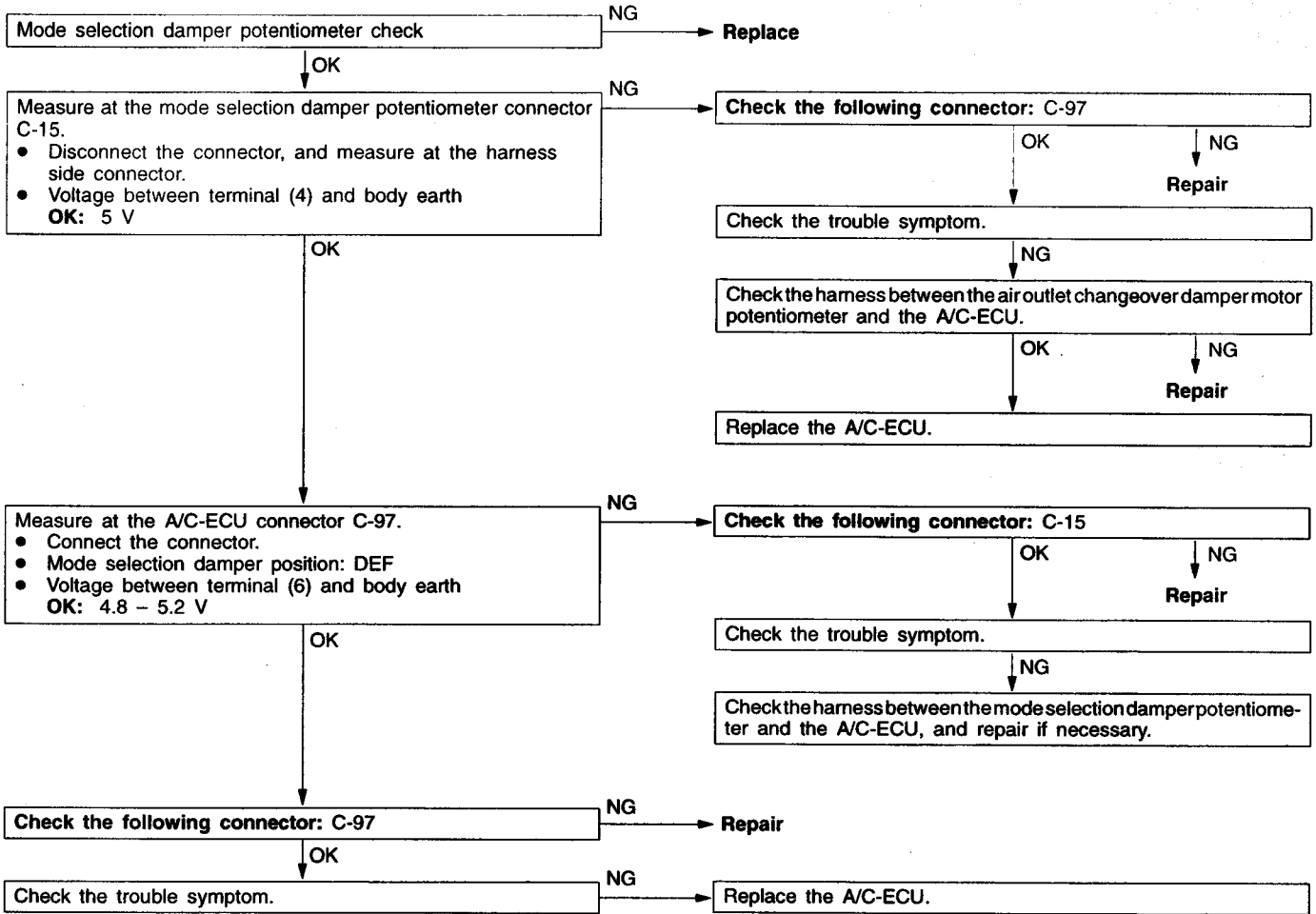

Code No.41 Drive system of blend air damper motor assembly	Probable cause
This diagnosis code is output if the motor drive circuit is defective.	<ul style="list-style-type: none"> ● Malfunction of the blend air damper motor assembly ● Malfunction of connector ● Malfunction of harness ● Malfunction of the A/C-ECU

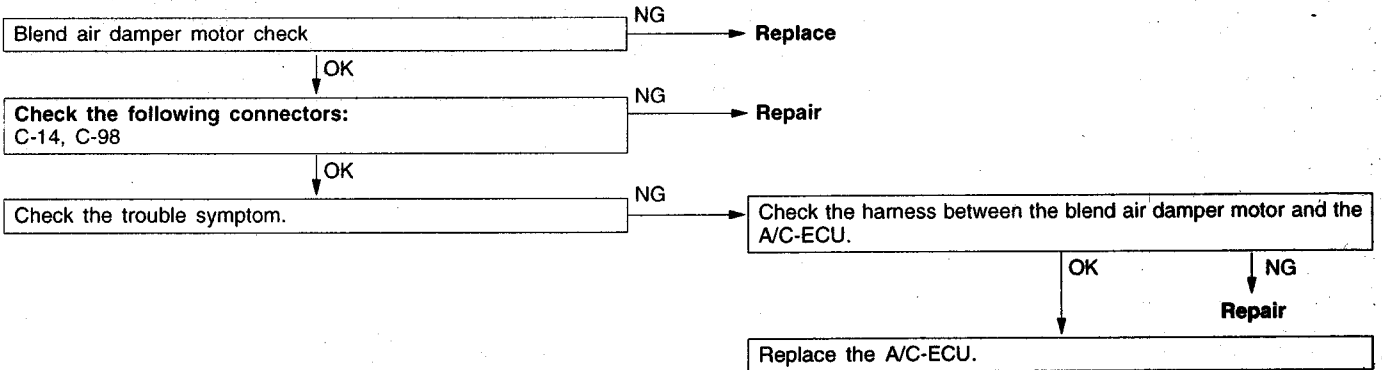

Code No.42 Drive system of mode selection damper motor assembly	Probable cause
This diagnosis code is output if the motor drive circuit is defective.	<ul style="list-style-type: none"> ● Malfunction of the mode selection damper motor assembly ● Malfunction of connector ● Malfunction of harness ● Malfunction of the A/C-ECU

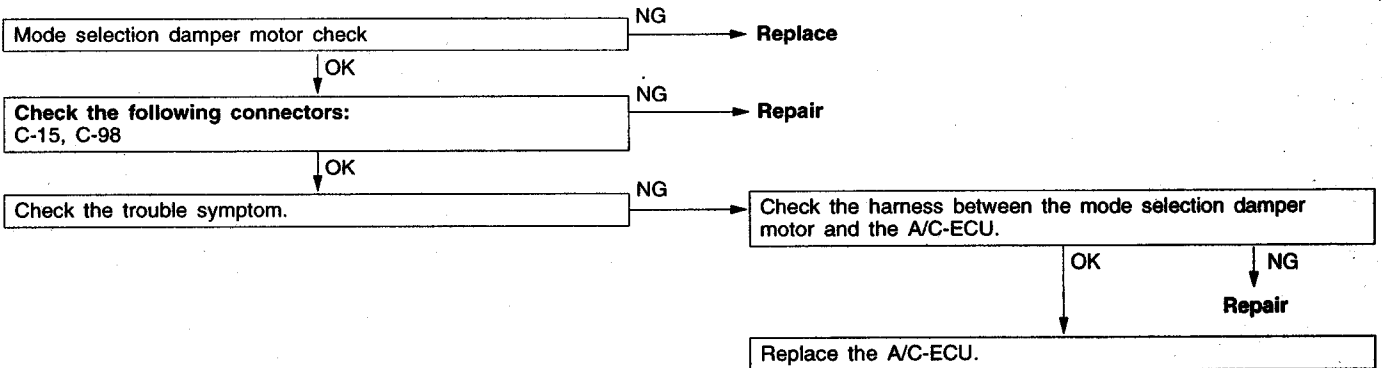

55-10 HEATER, AIR CONDITIONER AND VENTILATION – Troubleshooting

INSPECTION CHART FOR TROUBLE SYMPTOMS

Trouble symptom	Inspection procedure No.	Reference page
Communication with the MUT-II is not possible.	1	55-11
Air conditioner does not operate.	2	55-12
A/C graphic display on control panel is blank.	3	55-13
Temperature cannot be set.	4	55-13
A/C outlet air temperature does not increase.	5	55-13
A/C outlet air temperature does not decrease.	6	55-13
Blower does not operate.	7	55-14
Blower air amount cannot be changed.	8	55-15
Air outlet port cannot be changed.	9	55-15
Inside/outside air selection is not possible.	10	55-16
Defroster function does not operate.	11	55-17
Radiator fan does not operate.	12	55-18
Condenser fan does not operate.	13	55-20
A/C-ECU power supply circuit check	14	55-22
A/C compressor control circuit check	15	55-23

INSPECTION PROCEDURE FOR TROUBLE SYMPTOMS

Inspection procedure 1

Communication with the MUT-II is not possible.	Probable cause
If communication with all other systems is not possible, there is a high possibility that there is a malfunction of the diagnosis line. If communication with only the A/C is not possible, the cause is probably a malfunction of the diagnosis line or of the A/C-ECU power supply system (earth).	<ul style="list-style-type: none"> • Malfunction of connector or harness • Malfunction of A/C-ECU

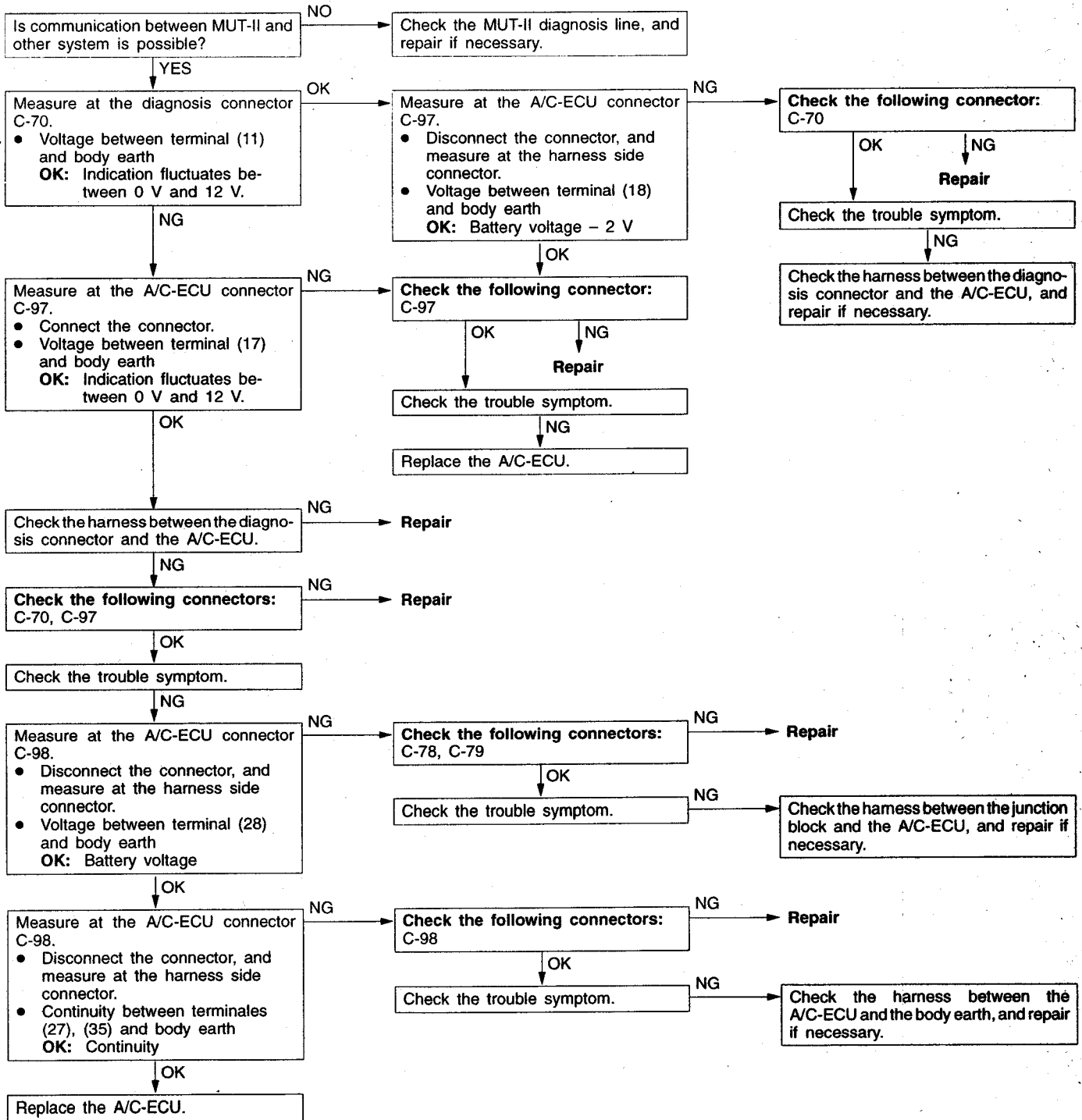

Inspection procedure 2

Air conditioner does not operate.	Probable cause
<p>If the A/C does not operate when the A/C switch is on and the temperature setting is at 17°C, the cause is probably insufficient refrigerant, or a malfunction of the blower or of the magnet clutch power supply.</p>	<ul style="list-style-type: none"> • Malfunction of blower • Insufficient refrigerant • Malfunction of magnetic clutch • Malfunction of air thermo sensor • Malfunction of magnetic clutch relay • Malfunction of refrigerant temperature switch • Malfunction of dual pressure switch • Malfunction of connector or harness • Malfunction of engine-ECU • Malfunction of A/C-ECU

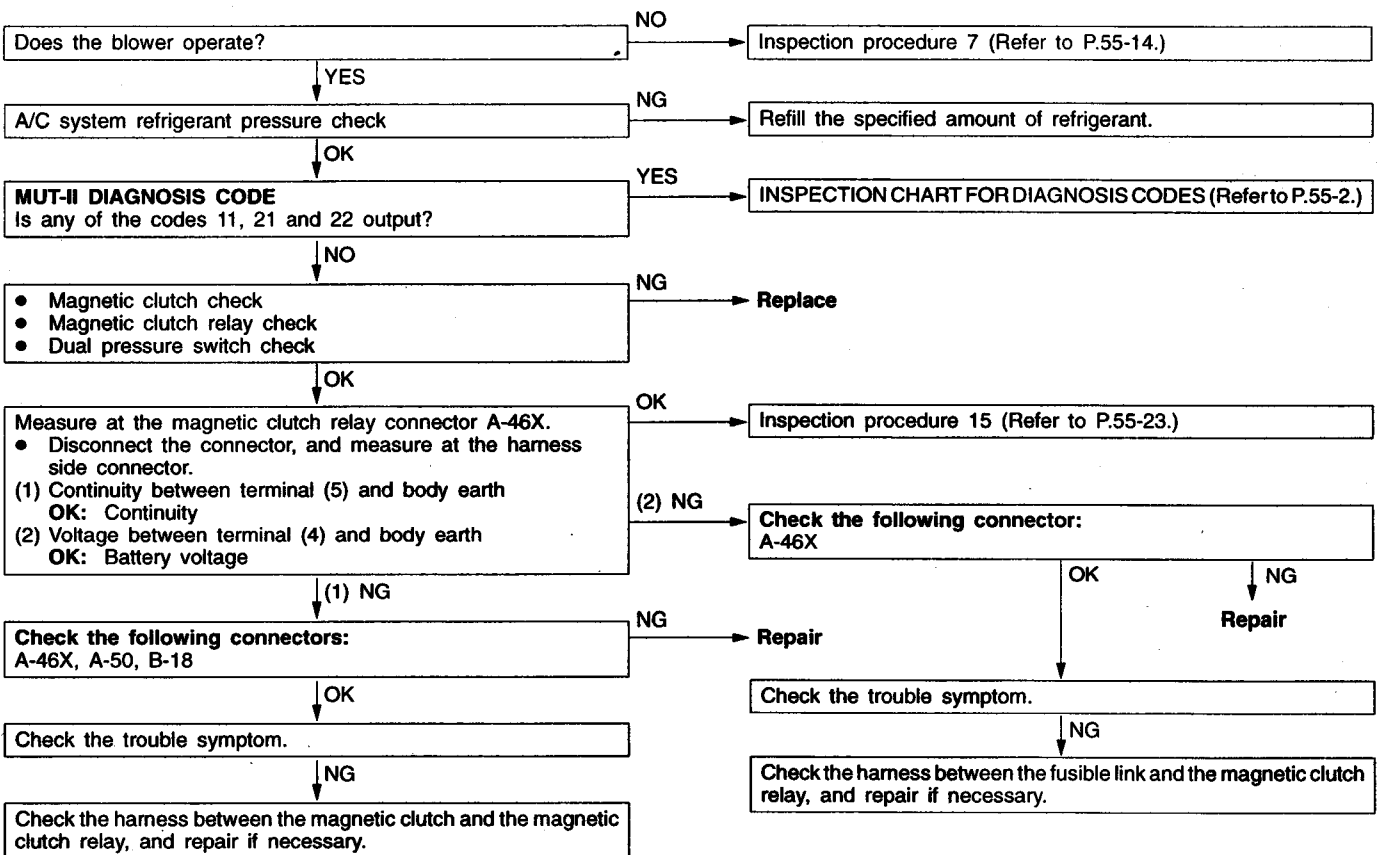

Inspection procedure 3

A/C graphic display on control panel is blank.	Probable cause
The cause is probably a malfunction of the A/C-ECU power supply system (earth).	<ul style="list-style-type: none"> ● Malfunction of connector or harness ● Malfunction of A/C-ECU

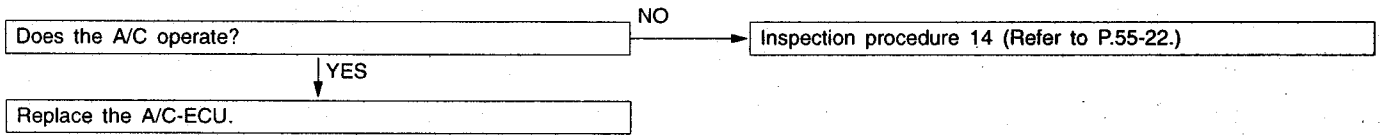

Inspection procedure 4

Temperature cannot be set.	Probable cause
The cause is probably a malfunction of the temperature setting signal input system or output system.	<ul style="list-style-type: none"> ● Malfunction of connector or harness ● Malfunction of A/C-ECU

Inspection procedure 14 (Refer to P.55-22.)

Inspection procedure 5

A/C outlet air temperature does not increase.	Probable cause
If the outlet air temperature does not increase when the temperature setting is increased, the cause is probably a sensor malfunction or a problem with operation of the blend air damper. The MUT-II can be used to check the diagnosis codes in order to check the cause of the problem for each separate system.	<ul style="list-style-type: none"> ● Malfunction of blend air damper potentiometer ● Malfunction of blend air damper motor ● Malfunction of blend air damper ● Malfunction of connector or harness ● Malfunction of interior temperature sensor ● Malfunction of A/C-ECU

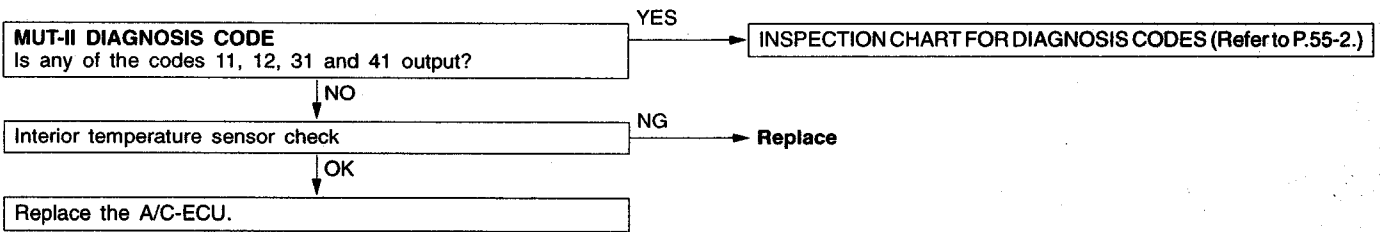

Inspection procedure 6

A/C outlet air temperature does not decrease.	Probable cause
If the outlet air temperature does not decrease when the temperature setting is decreased, the cause is probably a problem in A/C system operation due to a sensor error, or a problem with operation of the blend air damper. The MUT-II can be used to check the diagnosis codes in order to check the cause of the problem for each separate system.	<ul style="list-style-type: none"> ● Malfunction of blend air damper potentiometer ● Malfunction of blend air damper motor ● Malfunction of air thermo sensor ● Malfunction of connector or harness ● Malfunction of blend air damper ● Malfunction of A/C-ECU

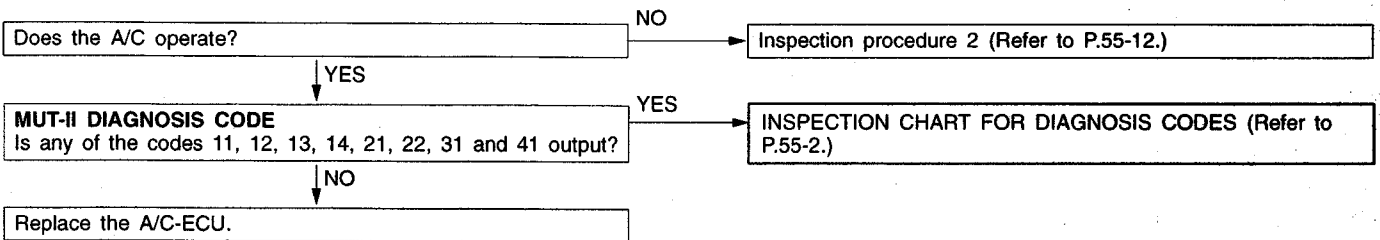

Inspection procedure 7

Blower does not operate.	Probable cause
If no air comes out of the blower even though the blower switch is on, the cause is probably a malfunction of the blower motor relay circuit.	<ul style="list-style-type: none"> ● Malfunction of blower motor relay ● Malfunction of blower motor ● Malfunction of connector or harness ● Malfunction of A/C-ECU

